



EUROMAG
INTERNATIONAL

Measure > Sense > Innovate

SENSOR MUT2200US

Electromagnetic flowmeter



The electromagnetic flowmeter for all applications



DS100-2-US



Sensor MUT2200US

MUT2200US sensors represent the state of the art of Euromag International production for water cycle and process applications. The new structure for the generation of the magnetic field and the innovative route of the signal generated by the electrodes, provide a sensor with an extremely wide measurement range:

EL= Extended Linearity

This new sensors series follows the successful tradition of the MUT2200US, introducing a measurement range of more than 1:1000 without linearization software. These kinds of performances allow very accurate measures on a wide flowrate range and to count lower flow rates that, before, would have been reset because of the effect of the converters cut off.

This flanged sensors series bases its operation on the Faraday Principle, by which a conductor crossing a magnetic field generates a potential perpendicularly orientated to the same field.

In this case the flow tube made in stainless steel AISI 304 is equipped with carbon steel or stainless steel flanges, two coils are installed on the top and inferior part; the magnetic field, generated by the electric current crossing the coil, induces in the electrodes a difference in the potential proportional to the flow rate.

With the aim of measuring such potential of very low values, the interior of the flow tube is electrically insulated, thus the process liquid is no longer in contact neither with the material of the flow tube nor with that of the flange.

The converter used generates the current supplying the coil, acquires the electrodes difference of potential, process the signal to calculate the flowrate and administers the communication with the exterior.

The entire sensor, when installed in the separate version, has a degree of protection IP68 suitable for a permanent immersion in water up to a depth of 4.92 ft thanks to a welded plate structure containing the coil and the electrodes.



Body and flanges

The flange and the sensor external surface are acrylic painted. This treatment gives the sensor an excellent resistance to water, even in permanent immersion. When special ambient conditions require it, the MUT2200US may be supplied in stainless steel, flange included or special painting for C4 class environments.

Internal lining

The standard internal insulating lining is in PTFE for diameters from 1/2" to 4", in hard rubber (Ebonite) for diameters equal or bigger than 5". On request, sensors may be supplied coated with PTFE with diameters bigger than 4". The suitable temperature is limited by the type of internal lining used.

Electrodes

Standard electrodes in Hastelloy C guarantee a wide compatibility with different kind of liquids; if required, they may be supplied in Hastelloy B, Titanium, Tantalum or Platinum.

Coupling and sensor connection

MUT2200US sensors may be coupled with any Euromag converters. In the separate version the sensor is connected to the converter by means of cables whose length depends on the liquid conductivity; the maximum length shall not exceed 328 feet (98 feet in combination with battery operated electronics).

When installed in plastic or coated pipe lines, sensors may require the use of two grounding rings, which are inserted between the flange and the counter flange. On sensors greater or equal than 2" an empty pipe electrode is supplied as a standard (empty pipe alarm).

Reference standards

The Euromag magnetic meters are marked CE and are manufactured according to the following standards:

- Certified to NSF ANSI61
- 2014/35/EU - EN 61010-1:2013 (LVD)
- 2014/30/EU - EN 61326-1:2013 (EMC)
- OIML R49-1:2013
- European directive 2014/32/EU (MID)
- 2014/34/UE - IEC 60079 - 0, IEC 60079 - 18 (ATEX - IECEx) Separate version
- EN ISO 15609-1 and EN ISO 15614-1
- UNI EN ISO 12944-2, painting for C4 class environments (on request)
- PTFE conform to the norms WRAS, FDA, DPR 777/82 e DM 21/09/773
- Ebonite conform to the norms WRAS, FDA



MUT2200US - MC608A

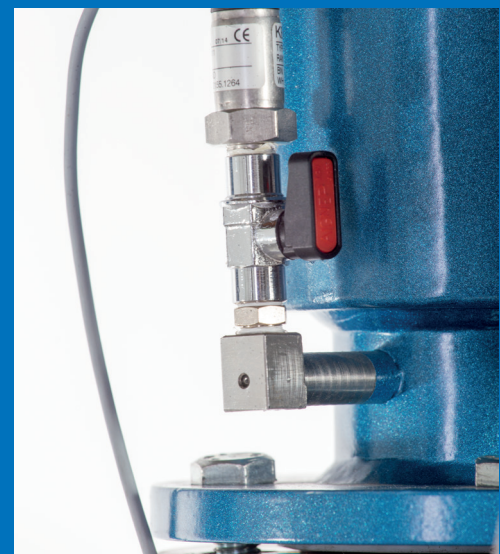

Integrated pressure sensor



MUT2200US - MC608B - GSM - Pressure

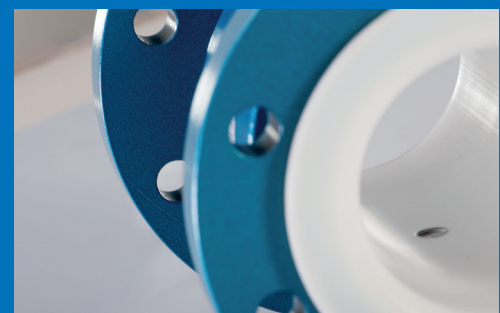

MUT2200US - PTFE liner

Calibration and maximum error

MUT2200US sensors belong to the reference Group B1 (ISO 11631). Each sensor is calibrated on an hydraulic bench equipped with a reference weighting system and SIT certified. The uncertainty of the calibration is equal to 0.2% +/- 0.08 inch/s. The repeatability is in the order of 0.1%.

Maximum Permissible Error is within the limits indicated in the following graph:

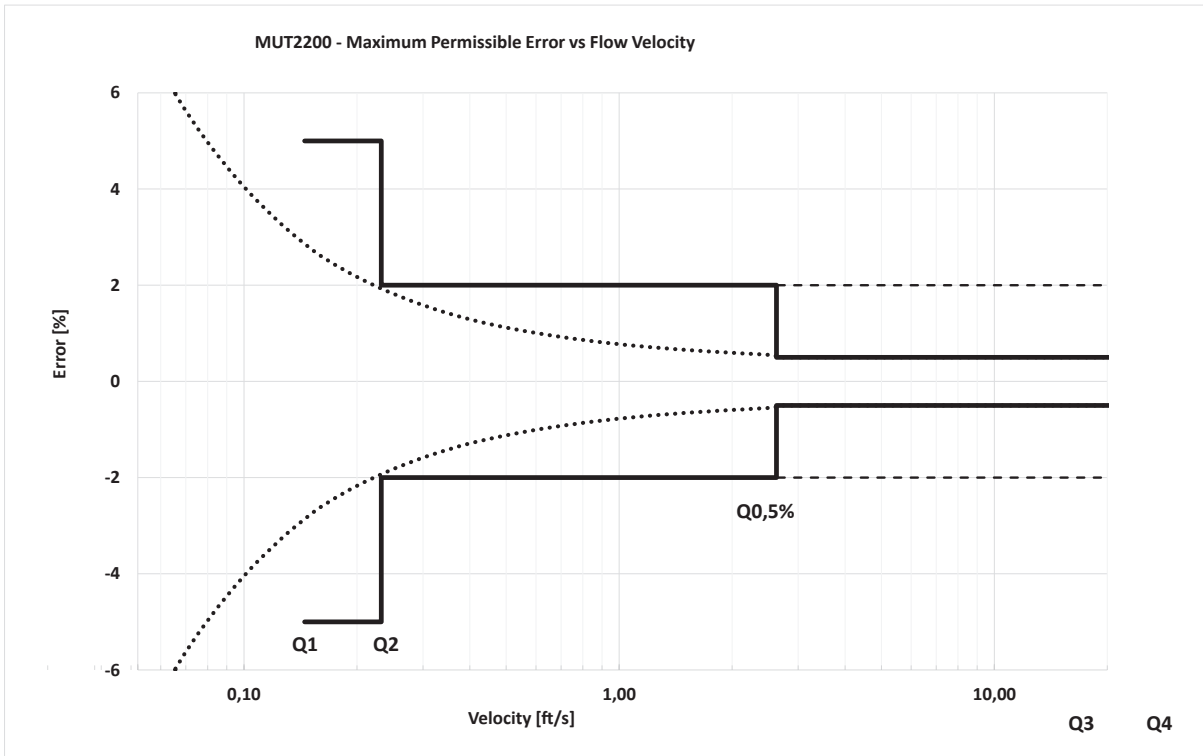

Flow rates chart

Sensor diameter	Flow rate [gpm]					Ratio Q3/Q1
	Min. Q1	Trans. Q2	Q0,5%	Perm. Q3	Overl. Q4	
1"	0.35	0.56	6.16	44.03	55.04	125
1" 1/4	0.35	0.56	10.13	44.03	55.04	125
1" 1/2	0.56	0.90	15.85	70.45	88.06	125
2"	0.88	1.41	24.88	110.07	137.59	125
2" 1/2	1.41	2.25	42.05	176.11	220.14	125
3"	2.22	3.55	63.84	277.38	346.73	125
4"	3.52	5.64	99.50	440.29	550.36	125
5"	5.64	9.02	155.42	704.46	880.57	125
6"	8.81	14.09	224.55	1,100.72	1,375.90	125
8"	14.09	22.54	398.46	1,761.15	2,201.43	125
10"	22.19	35.50	616.40	2,773.81	3,467.26	125
12"	35.22	56.36	880.57	4,402.87	5,503.58	125
14"	56.36	90.17	1,232.80	7,044.59	8,805.73	125
16"	56.36	90.17	1,585.03	7,044.59	8,805.73	125

Sensor diameter	Flow rate [gpm]					Ratio Q3/Q1
	Min. Q1	Trans. Q2	Q0,5%	Perm. Q3	Overl. Q4	
18"	110.07	176.11	2,025.32	11,007.17	13,758.96	100
20"	110.07	176.11	2,509.63	11,007.17	13,758.96	100
24"	220.14	352.23	3,610.35	17,611.47	22,014.34	80
28"	220.14	352.23	4,843.15	17,611.47	22,014.34	80
32"	440.29	704.46	6,384.16	27,738.06	34,672.58	63
36"	440.29	704.46	8,101.28	27,738.06	34,672.58	63
40"	880.57	1,408.92	9,994.51	44,028.67	55,035.84	50
48"	1,408.92	2,254.27	14,397.38	70,445.87	88,057.34	50
56"	2,201.43	3,522.29	19,548.73	110,071.68	137,589.59	50
60"	3,522.29	5,635.67	22,454.62	176,114.68	220,143.35	50
64"	5,547.61	8,876.18	25,536.63	277,380.62	346,725.78	50
72"	8,805.73	14,089.17	32,361.07	440,286.70	550,358.38	50
80"	14,089.17	22,542.68	40,066.09	704,458.72	880,573.40	50

MUT2200US general features

Flow tube material		AISI 304 (standard), AISI 316																
Flanges material		Carbon steel painted (standard), AISI 304, AISI 316																
Electrodes material		Hastelloy C (standard), Hastelloy B, Titanium, Tantalum, Platinum																
Internal lining and liquid temperature		Internal lining								Liquid temperature								
		PTFE								Standard -104 F/+266 F (up to +356 F on request)								
		Ebonite								-104 F / +176 F								
Available sizes		mm	15	20	25	32	40	50	65	80	100	125	150	200	250	300	350	400
		Inches	1/2"	3/4"	1"	1 1/4"	1 1/2"	2"	2 1/2"	3"	4"	5"	6"	8"	10"	12"	14"	16"
		mm	450	500	600	700	800	900	1000	1200	1300	1400	1500	1600	1700	1800	2000	
		Inches	18"	20"	24"	28"	32"	36"	40"	48"	52"	56"	60"	64"	68"	72"	80"	
Flange standards available		ANSI 150, ANSI 300, ANSI 600, ANSI 900, EN1092-1, DIN 2501, BS 4504, AS 2129 (TABLE D - E - F), AS 4087, ISO 7005-1, KS 10K																
Protection Degree		IP68 4.92 ft continuous immersion (EN 60529)																
Compatible converters		MC608 A/B/R/P/I, MC406																
Electrical connections		Cable glands M20 x 1.5 + terminal block + sealing resin																

Pressure port integrated

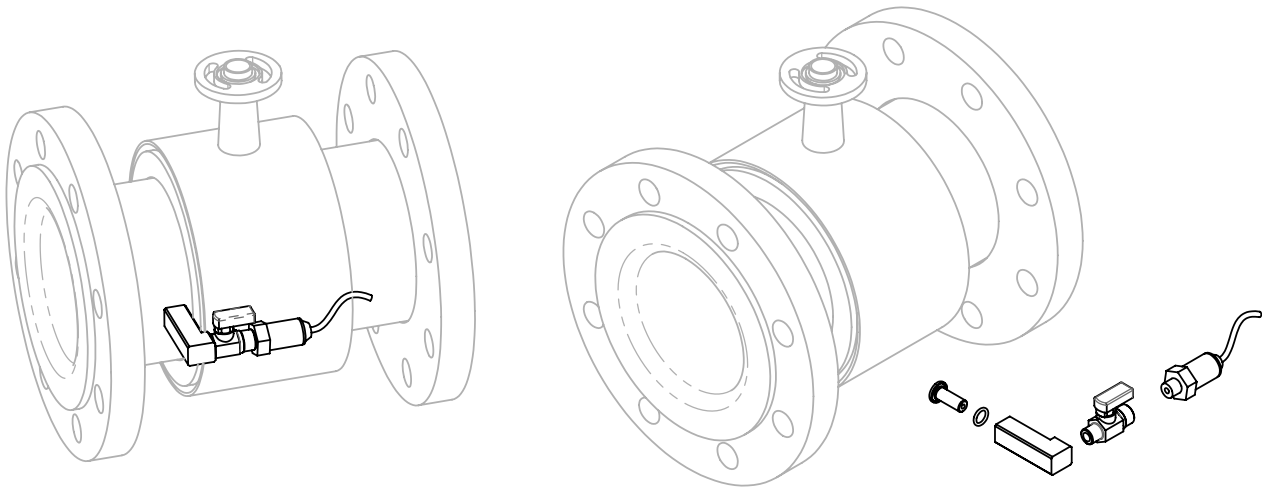

Applications

MUT2200US sensors are suitable for any on-line application. These sensors are typically used in the measure of potable or not potable water, industrial waste water, industrial process liquids, muds and concretes.

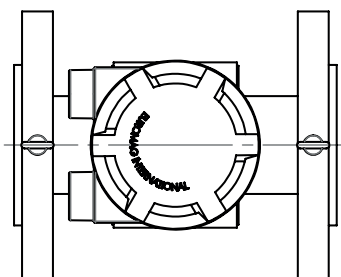
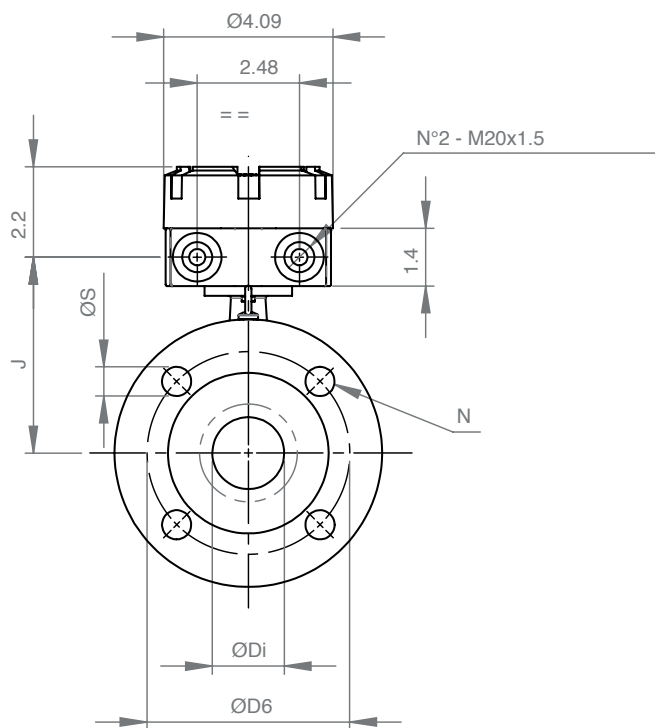
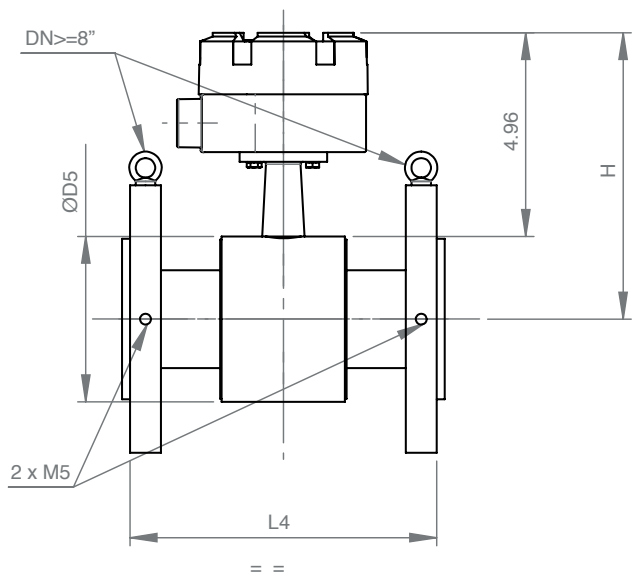

MUT2200US ANSI 150

MUT2200US ANSI 300

SIZE	D5	L4	J	Di	D6	N	S	H
1/2"	3.31	7.87(+0/-0.12)	4.42	0.44	2.37	4	5/8	6.61
3/4"	3.31	7.87(+0/-0.12)	4.42	0.67	2.75	4	5/8	6.61
1"	2.91	7.87(+0/-0.12)	4.22	0.93	3.13	4	5/8	6.42
1" 1/4	3.27	7.87(+0/-0.12)	4.40	1.24	3.50	4	5/8	6.59
1" 1/2	3.46	7.87(+0/-0.12)	4.50	1.47	3.87	4	5/8	6.69
2"	4.02	7.87(+0/-0.12)	4.77	1.86	4.75	4	3/4	6.97
2" 1/2	4.49	7.87(+0/-0.12)	5.01	2.48	5.50	4	3/4	7.20
3"	5.00	7.87(+0/-0.12)	5.26	2.95	6.00	4	3/4	7.46
4"	6.34	9.84(+0/-0.12)	5.93	3.83	7.50	8	3/4	8.13
5"	7.36	9.84(+0/-0.12)	6.44	4.79	8.50	8	7/8	8.64
6"	8.27	11.81(+0/-0.12)	6.90	5.84	9.50	8	7/8	9.09
8"	10.28	13.78(+0/-0.12)	7.90	7.68	11.75	8	7/8	10.10
10"	12.56	17.72(+0/-0.2)	9.04	9.65	14.25	12	1	11.24
12"	14.61	19.69(+0/-0.2)	10.07	12.12	17.00	12	1	12.26
14"	15.91	21.65(+0/-0.2)	10.72	13.29	18.75	12	1 1/8	12.91
16"	17.91	23.62(+0/-0.2)	11.72	15.21	21.25	16	1 1/8	13.92
18"	20.43	17.72(+0/-0.28)	12.98	17.21	22.74	16	1 1/4	15.18
20"	22.44	19.69(+0/-0.35)	13.98	19.21	25.00	20	1 1/4	16.18
24"	26.93	23.62(+0/-0.35)	16.23	23.13	29.50	20	1 3/8	18.43
28"	30.83	27.56(+0/-0.35)	18.18	27.06	34.00	28	1 3/8	20.37
32"	34.84	31.5(+0/-0.35)	20.19	30.98	38.50	28	1 5/8	22.38
36"	39.21	35.43(+0/-0.59)	22.37	34.98	42.75	32	1 5/8	24.57
40"	43.23	39.37(+0/-0.59)	24.38	38.90	47.24	36	1 5/8	26.57
48"	51.65	47.24(+0/-0.59)	28.59	46.74	56.00	44	1 5/8	30.79
56"	59.53	55.12(+0/-0.59)	32.53	54.58	65.00	48	1 7/8	34.72
60"	63.46	59.06(+0/-0.59)	34.50	58.43	69.29	52	1 7/8	36.69
64"	67.40	62.99(+0/-0.59)	36.46	62.43	-	-	-	38.66
72"	75.67	70.87(+0/-0.59)	40.60	70.35	-	-	-	42.80
80"	83.54	78.74(+0/-0.59)	44.54	78.12	-	-	-	46.73

SIZE	D5	L4	J	Di	D6	N	S	H
1/2"	3.31	7.87(+0/-0.12)	4.42	0.44	2.63	4	5/8	6.61
3/4"	3.31	7.87(+0/-0.12)	4.42	0.67	3.25	4	3/4	6.61
1"	2.91	7.87(+0/-0.12)	4.22	0.93	3.50	4	3/4	6.42
1" 1/4	3.27	7.87(+0/-0.12)	4.40	1.24	3.87	4	3/4	6.59
1" 1/2	3.46	7.87(+0/-0.12)	4.50	1.47	4.50	4	7/8	6.69
2"	4.02	7.87(+0/-0.12)	4.77	1.86	5.00	8	3/4	6.97
2" 1/2	4.49	7.87(+0/-0.12)	5.01	2.48	5.87	8	7/8	7.20
3"	5.00	7.87(+0/-0.12)	5.26	2.95	6.63	8	7/8	7.46
4"	6.34	9.84(+0/-0.12)	5.93	3.91	7.87	8	7/8	8.13
5"	7.36	9.84(+0/-0.12)	6.44	4.79	9.25	8	7/8	8.64
6"	8.27	11.81(+0/-0.12)	6.90	5.92	10.63	12	7/8	9.09
8"	10.28	13.78(+0/-0.12)	7.90	7.68	13.00	12	1	10.10
10"	12.56	17.72(+0/-0.2)	9.04	9.80	15.25	16	1 1/8	11.24
12"	14.61	19.69(+0/-0.2)	10.07	11.81	17.75	16	1 1/4	12.26
14"	15.91	21.65(+0/-0.2)	10.72	12.98	20.25	20	1 1/4	12.91
16"	17.91	23.62(+0/-0.2)	11.72	14.90	22.50	20	1 3/8	13.92
18"	20.43	17.72(+0/-0.28)	12.98	16.82	24.75	24	1 3/8	15.18
20"	22.44	19.69(+0/-0.35)	13.98	18.74	27.00	24	1 3/8	16.18
24"	26.93	23.62(+0/-0.35)	16.23	22.50	32.00	24	1 5/8	18.43
28"	30.83	27.56(+0/-0.35)	18.18	26.43	37.00	28	1 3/4	20.37
32"	34.84	31.5(+0/-0.35)	20.19	30.19	41.50	28	1 7/8	22.38
36"	39.21	35.43(+0/-0.59)	22.37	34.03	46.00	32	2 1/8	24.57
40"	43.23	39.37(+0/-0.59)	24.38	37.87	45.50	32	1 3/4	26.57
48"	51.65	47.24(+0/-0.59)	28.59	45.64	54.00	32	2	30.79
56"	59.53	55.12(+0/-0.59)	32.53	53.24	63.00	28	2 3/8	34.72
60"	63.46	59.06(+0/-0.59)	34.50	57.09	67.00	32	2 3/8	36.69
64"	67.40	62.99(+0/-0.59)	36.46	60.93	-	-	-	38.66
72"	75.67	70.87(+0/-0.59)	40.60	68.77	-	-	-	42.80
80"	83.54	78.74(+0/-0.59)	44.54	76.30	-	-	-	46.73

MUT2200US - MC608 A/B/R*

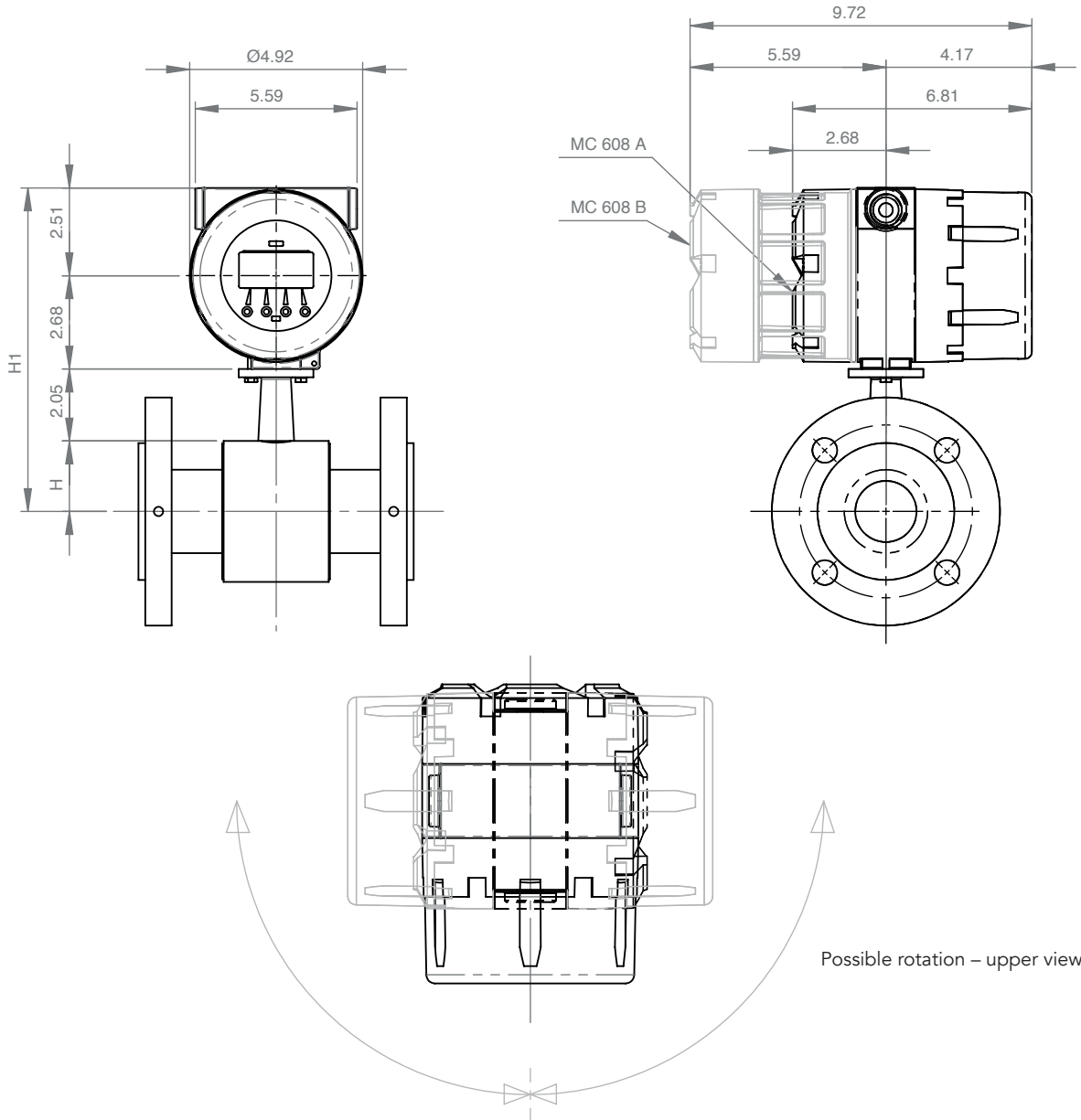

MC608 A/B/R*		
SIZE	H	H1
1"	1.46	8.66
1" 1/4	1.63	8.84
1" 1/2	1.73	8.94
2"	2.01	9.21
2" 1/4	2.24	9.45
3"	2.50	9.70
4"	3.17	10.37
5"	3.68	10.89
6"	4.13	11.34
8"	5.14	12.34
10"	6.28	13.48
12"	7.30	14.51
14"	7.95	15.16
16"	8.96	16.16

MC608 A/B/R*		
SIZE	H	H1
18"	10.22	17.42
20"	11.22	18.43
24"	13.46	20.67
28"	15.41	22.62
30"	16.42	23.62
32"	17.42	24.63
36"	19.61	26.81
40"	21.61	28.82
48"	25.83	33.03
56"	29.76	36.97
60"	31.73	38.94
64"	33.70	40.91
72"	37.83	45.04
80"	41.77	48.98

* B/R max DN24"

MUT2200US - MC406 HORIZONTAL - Up to 24"

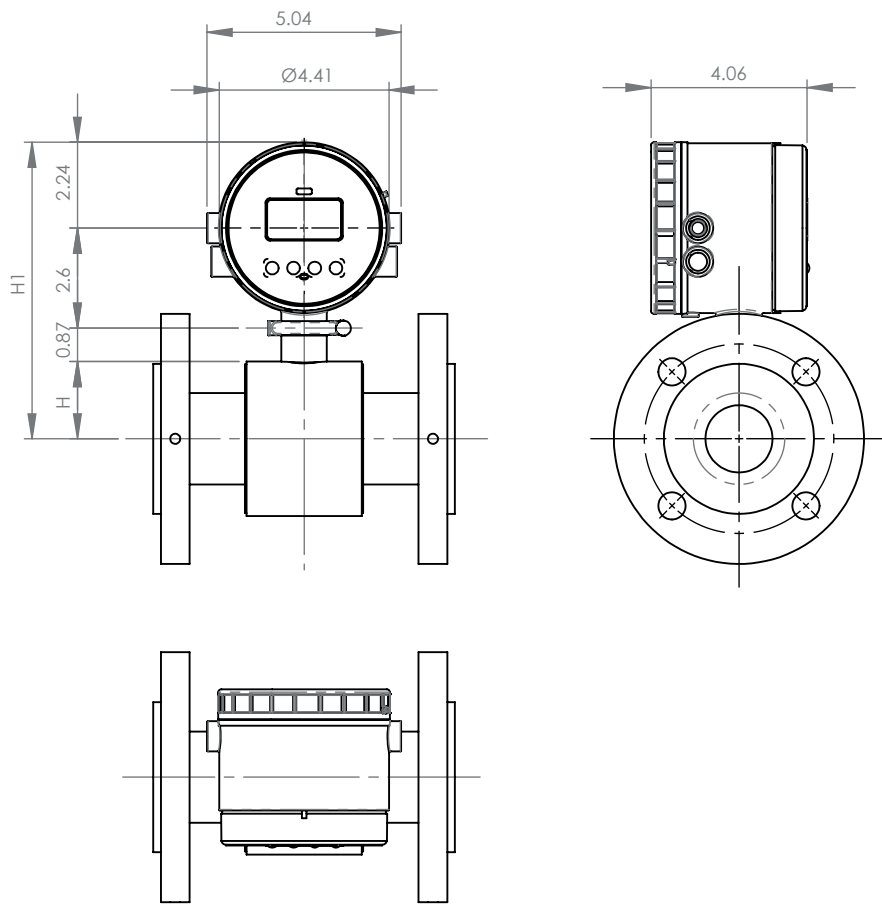

MC406 HORIZONTAL		
SIZE	H	H1
1"	1.46	7.15
1" 1/4	1.63	7.33
1" 1/2	1.73	7.43
2"	2.01	7.70
2" 1/4	2.24	7.94
3"	2.50	8.19
4"	3.17	8.86
5"	3.68	9.37
6"	4.13	9.83
8"	5.14	10.83
10"	6.28	11.97
12"	7.30	13.00
14"	7.95	13.65
16"	8.96	14.65
18"	10.22	15.91
20"	11.22	16.91
24"	13.46	19.16

MUT2200US - MC406 VERTICAL - Up to 24"

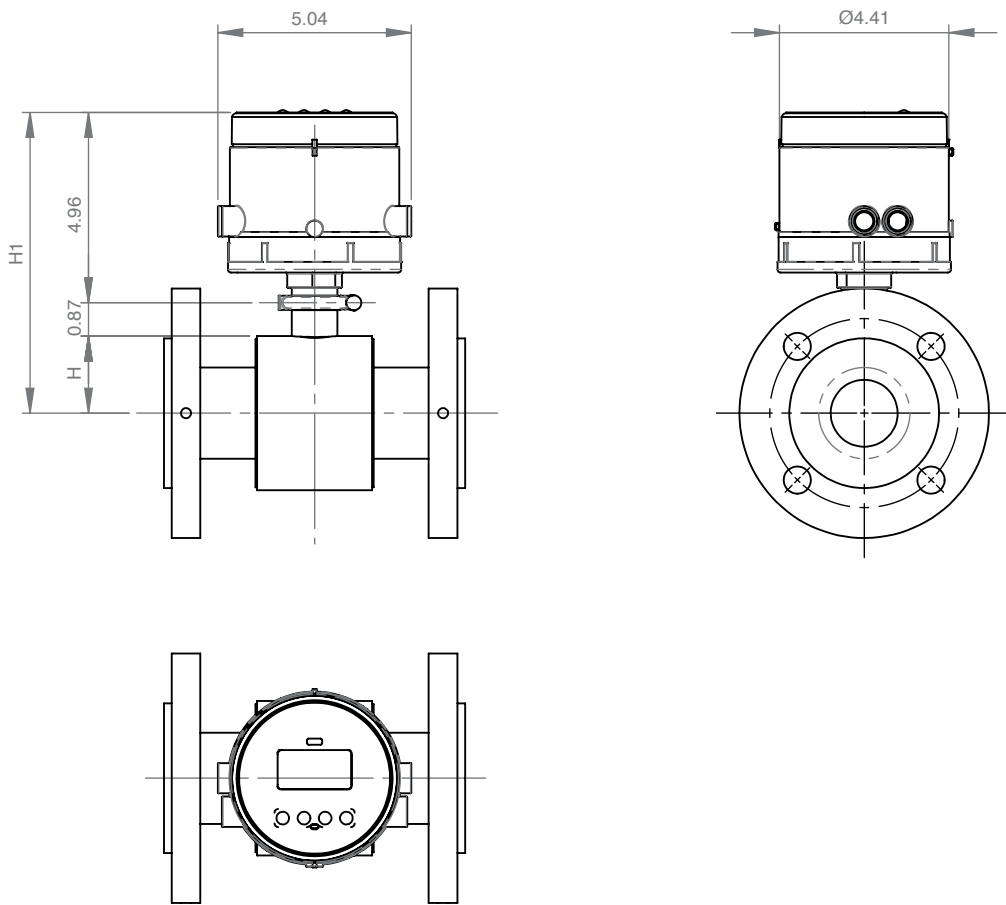

MC406 VERTICAL		
SIZE	H	H1
1"	1.46	7.28
1" 1/4	1.63	7.46
1" 1/2	1.73	7.56
2"	2.01	7.83
2" 1/4	2.24	8.07
3"	2.50	8.33
4"	3.17	9.00
5"	3.68	9.51
6"	4.13	9.96
8"	5.14	10.96
10"	6.28	12.11
12"	7.30	13.13
14"	7.95	13.78
16"	8.96	14.78
18"	10.22	16.04
20"	11.22	17.05
24"	13.46	19.29

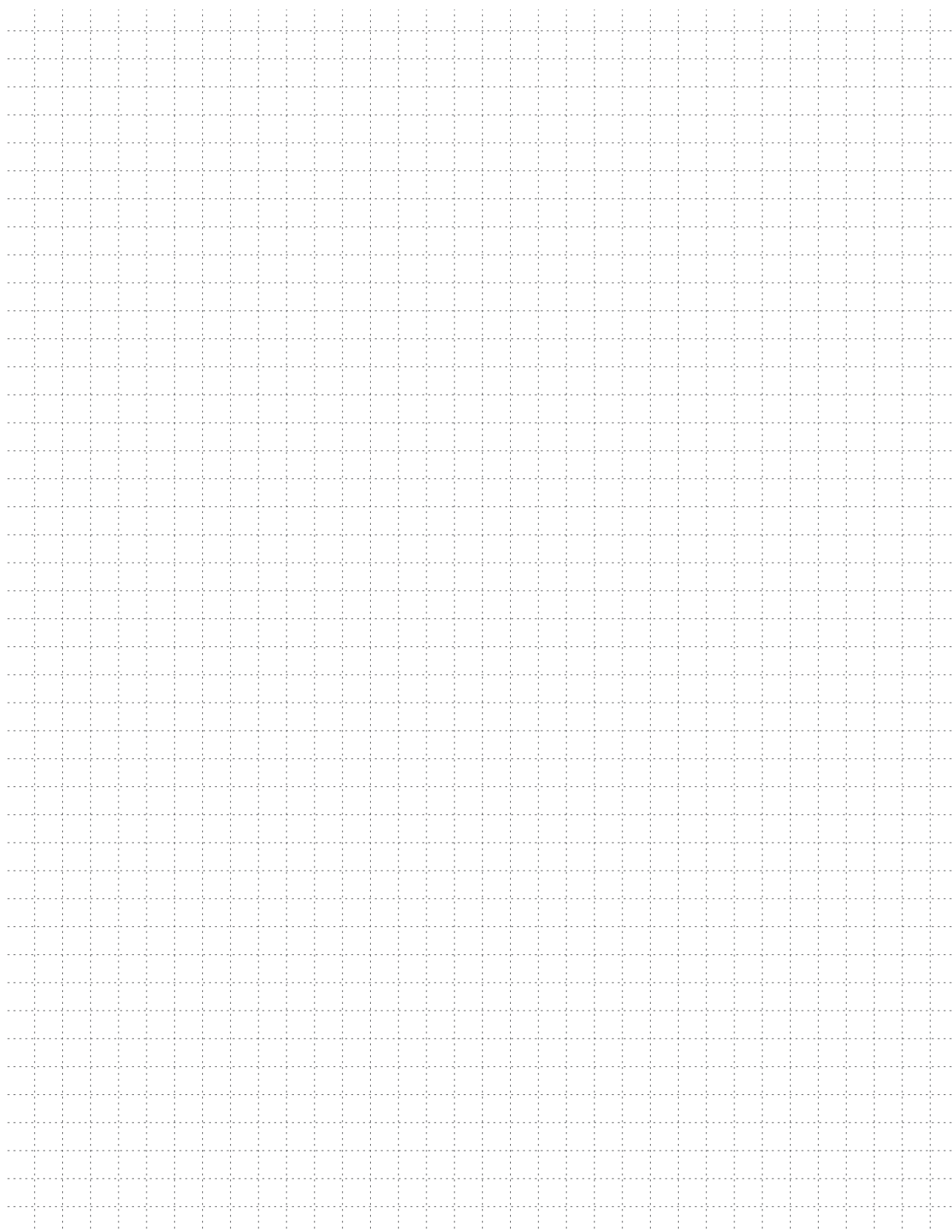



Measure > Sense > Innovate



EUROMAG
INTERNATIONAL

Measure > Sense > Innovate



EUROMAG INTERNATIONAL Srl

Via della Tecnica, 20 - 35035 Mestrino (Padova) Italia
Tel. +39 049.9005064 - Fax +39 049.9007764

www.euromag.com - www.euromagdata.com
euromag@euromag.com