



EUROMAG
INTERNATIONAL

Measure > Sense > Innovate



ELECTROMAGNETIC FLOWMETERS

Sensors

Instruction manual

MUT2200EL/US

MUT2300 /US

MUT1000EL/US

MUT1100J

MUT1222

MUT2660

MUT2770



CAREFULLY READ THESE INSTRUCTIONS AND KEEP THEM IN A SAFE PLACE



ENGLISH
Translation of the original instructions
TD-217-1-ENG



This document must be delivered to the user before machine installation and commissioning.

Symbols used in this manual

In order to draw the attention of all personnel working with the equipment supplied by EUROMAG INTERNATIONAL, the points of particular importance described in this manual are highlighted with graphic signs and different colors that will make them easily identifiable.

Legend



CAUTION! This sign indicates a risk of electric shock! All operations marked with this sign must be performed exclusively by qualified technical personnel.



CAUTION/WARNING: This symbol indicates vital information and points to be observed. Please refer to the related documents.



NOTE: This symbol indicates information and points of particular importance to be observed.

READ THE INSTRUCTIONS CAREFULLY AND KEEP THEM IN A SAFE PLACE

This manual can be downloaded from the website www.euromag.com in the Area Download section.

We want you to save time and money!

We assure you that, having read this manual thoroughly, you will be able to perform correct installation and fully use the product in total safety.

1	INTRODUCTION	6
1.1	MANUFACTURER'S STATEMENT.....	6
1.2	PACKAGING VERIFICATION.....	6
1.3	PRELIMINARY NOTES.....	7
1.4	PRODUCT IDENTIFICATION.....	7
1.5	APPLICATIONS.....	8
2	PRODUCT DESCRIPTION	9
2.1	OPERATING PRINCIPLE.....	9
2.1.1	Bidirectional reading.....	9
2.2	AVAILABLE VERSIONS.....	10
2.2.1	Flanged sensors.....	10
	• MUT2200EL – Full Bore.....	10
	• MUT2300 – Reduced Bore.....	10
2.2.2	Wafer sensors.....	10
	• MUT1000EL - Wafer.....	10
	• MUT1100J - Wafer in plastic material.....	10
2.2.3	Insertion sensors.....	10
	• MUT1222.....	10
	• MUT2660.....	10
	• MUT2770.....	10
2.3	TYPES OF INSTALLATION OF THE SENSOR.....	10
3	INSTALLATION	11
3.1	STORAGE AND MOVING.....	11
3.1.1	Storage.....	11
3.1.2	Moving.....	11
3.2	GENERAL INSTALLATION REQUIREMENTS.....	12
3.2.1	Vibrations.....	12
3.2.2	Magnetic fields.....	12
3.2.3	Negative pressure.....	13
3.2.4	Protection from direct sunlight.....	13
3.2.5	Operating temperatures.....	13
3.3	INSTALLATION CONDITIONS.....	14
3.3.1	Positioning in relation to the plant.....	14
3.3.2	Important guidelines for correct installation.....	14
3.4	INSTALLATION.....	18
3.4.1	Important instructions on installation.....	18
3.4.2	Sensor support.....	19
3.4.3	Tightening torque.....	19
	• Flanged sensors.....	19
	• Wafer Sensors.....	20
3.4.4	Underground installations.....	22
3.5	HOW TO AVOID AIR POCKETS IN THE PIPELINES.....	23
3.6	INSTRUCTIONS FOR DIAMETER REDUCTION.....	27

4	POTENTIAL EQUALIZATION	28
4.1	GENERAL INDICATIONS	28
4.2	PLASTIC PIPES	29
4.3	METAL PIPES	30
4.4	METAL PIPES WITH INSULATING ADAPTERS	30
4.5	METAL AND PLASTIC PIPES	31
4.6	PIPES EQUIPPED WITH CATHODIC PROTECTION	31
5	ELECTRICAL CONNECTION	32
5.1	SEPARATE VERSION SENSOR CONNECTION	32
5.2	ELECTRICAL DIAGRAMS	33
5.2.1	Connection with standard single-shielded electrode cable	33
5.2.2	Connection with standard double-shielded electrode cable	33
5.3	SEPARATION CABLES	34
6	PRESSURE TAP	35
7	INSERTION METERS	36
7.1	INTRODUCTION	36
7.1.1	Operating principle	36
7.2	GENERAL INSTALLATION REQUIREMENTS	37
7.2.1	Care of the device	37
7.2.2	Alignment of the electrodes in relation to the flow	38
7.3	MUT1222	39
7.3.1	Dimensions and main features	39
7.3.2	Calculation of the insertion depth	40
7.3.3	Installation of the sensor	41
7.3.3.1	Preparation of the pipe	41
7.3.3.2	Assembly of the flowmeter	41
7.3.4	Installation on non-metallic pipes using a saddle bracket	42
7.3.5	Flowmeter grounding	42
7.4	MUT2660	43
7.4.1	Dimensions and main features	43
7.4.2	Calculation of the insertion depth	44
7.4.3	Installation of the sensor	45
7.4.3.1	Preparation of the pipe	45
7.4.3.2	Installation of the flowmeter	45
7.4.4	Flowmeter grounding	46
7.5	MUT2770	47
7.5.1	Dimensions and main features	47
7.5.2	Calculation of the insertion depth	48
7.5.3	Installation of the sensor	49
7.5.3.1	Preparation of the pipe	49
7.5.3.2	Installation of the flowmeter	49
7.5.4	Flowmeter grounding	50

8	MAINTENANCE	50
8.1	BOLTS TIGHTENING	50
8.2	GROUNDING CHECK	50
8.3	CLEANING OF EBONITE COATINGS:	50
9	TROUBLESHOOTING	50
10	CERTIFICATIONS AND TECHNICAL FEATURES	50
11	SENDING THE FLOWMETER TO THE MANUFACTURER	51
11.1	REPAIR REQUEST FORM	51
12	PRODUCT DISPOSAL	53

1 INTRODUCTION



IMPORTANT WARNING! It is very important that all personnel working with the equipment have read and understood the instructions and indications provided in this manual, and that they follow them prior to using the equipment itself. The manufacturer assumes no responsibility for the consequences resulting from improper use by the worker.

The suitability of the device for particular purposes shall be the worker's responsibility.

The warranty will be considered void in cases of improper installation and use of devices (systems).

- The manufacturer shall bear no responsibility for any damage caused by improper use, improper installation, or tampering of own products. Installation, connection, commissioning, and maintenance must be carried out by personnel who are qualified and authorized for this purpose. The personnel in charge of the installation must make sure that the measurement system is properly connected as per the wiring diagram indicated in this document.
- The manufacturer shall bear no responsibility for any damages or injuries resulting from any misunderstanding of this manual. In order to avoid possible accidents to persons or things caused by incorrect interpretation of the instructions, the user must not proceed with operations and/or interventions on the converter if there are uncertainties or doubts regarding the operation(s) to be performed. We recommend contacting Assistance Service for clarifications in this regard for more precise instructions
- The manufacturer will be held responsible only if the converter will be used in its original configuration.

For applications that require high working pressures or use of substances that may be dangerous for people, the environment, equipment, or anything else: In case of pipe breakage, EUROMAG INTERNATIONAL recommends taking necessary precautions, such as adequate positioning and protection or installation of a guard or safety valve, *before* installing the **CONVERTER** in the **COMPACT** version.

The device contains live electrical components; therefore, installation, checks, and maintenance must be carried out by experienced and qualified personnel who are aware of all necessary precautions to be taken. Before opening any internal part, please disconnect the power supply.

1.1 MANUFACTURER'S STATEMENT

- » Stresses and loads possibly caused by earthquakes, strong winds, fire damage, vibrations, and natural disasters were not taken into account in the phase of machine designing.
- » Do not install the machine in such a way that it acts as a focus for pressure on the pipes. External loads were not taken into account in the device configuration.
- » While the device is working, the pressure, supply voltage, and/or temperature values indicated on the label or in this Operating Manual must not be exceeded.

1.2 PACKAGING VERIFICATION

At the moment of purchase and/or upon receipt of the product, the buyer is strongly advised to check the quality of the packaging, which must be intact, without visible dents, and completely and correctly closed.

When opening the packaging, also check that the product complies with the information on the packing list in terms of completeness of components/accessories.



NOTE: All EUROMAG INTERNATIONAL software is available on the USB stick that accompanies the product.

The software can also be downloaded from the website www.euromag.com by accessing the Download Area. A free registration will be required, after which you can download the configuration software for your product.

1.3 PRELIMINARY NOTES

Main parts of the electromagnetic flowmeter are:

- » **Sensor** – installed in the tube with the use of flanges and other joints
- » **Converter** – can be installed on the sensor (in compact version) or remotely (in remote version) connected with two pipes

Electromagnetic flowmeters have many important advantages compared to their mechanical counterparts, such as exceptional long-term stability, maximum process reliability, and zero maintenance. As a result, these sensors can provide accurate and reliable long-term measurements.

See the following paragraphs for more detailed information on correct installation.



NOTES:

Electromagnetic flowmeters are designed specifically to operate under the following basic conditions:

1. The liquid must be conductive;
2. Pipe must be always full and free from air and bubbles;
3. The input and output distances must be on recommended settings
4. The grounding instructions must be followed

1.4 PRODUCT IDENTIFICATION

Each **Sensor** manufactured by EUROMAG INTERNATIONAL has an identification plate (Fig. 1) that displays the following information::

IDENTIFICATION PLATE

- » **MODEL:** Sensor model
- » **S/N:** Sensor identification number
- » **DN:** Nominal diameter [inches or mm]
- » **PN:** Pressure diameter [psi or bar]
- » **TEMP.:** Maximum liquid temperature for process completion
- » **IP:** International degree of protection
- » **ELECTRODES:** Electrodes material composition
- » **LINING:** Lining material
- » **KA:** Calibration coefficient
- » **CE:** Marking

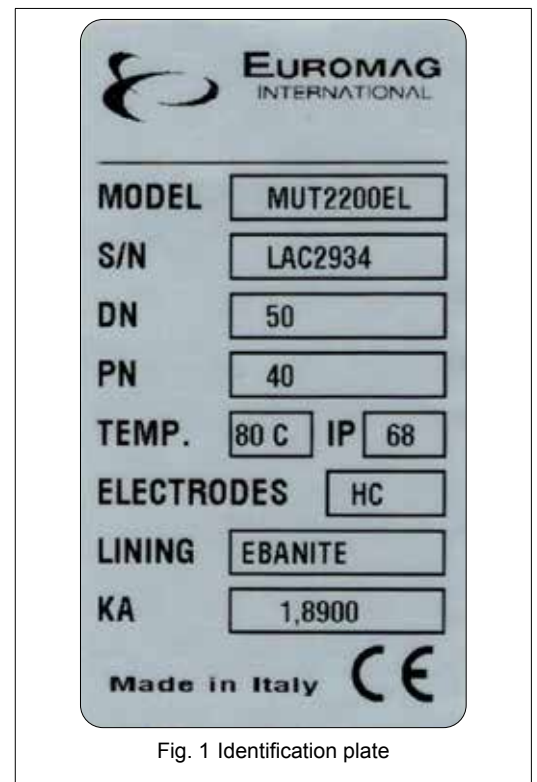

The identification plate must never be removed, damaged, or changed. It must also be kept clean from any dirt deposits, as the data contained are the only safe and unambiguous way to recognize the type of converter and be able to complete the repair request form attached to this manual.

1.5 APPLICATIONS

The sensors manufactured by the company EUROMAG are widely used in many applications where it is important to measure the flow rate of electrically conductive liquids. Various models can be used in different applications. The table below shows the typical applications according to the individual sensor models manufactured by EUROMAG.

	SENSOR MODEL						
	MUT2200EL/US	MUT2300/US	MUT1000EL/US	MUT1100J	MUT1222	MUT2660	MUT2770
Wastewater	X	X	X	X			
Industrial drainage water	X		X		X		X
Industrial wastewater	X	X	X				
Data acquisition for report and analysis	X	X	X	X	X	X	X
Night applications with very low flow rates		X					
Leakage control		X			X	X	X
Dams	X						X
Water distribution	X				X		
Distribution, municipal waters		X					
Sludge	X						
Water network management					X	X	X
Flow studies					X	X	X
Industry	X		X				
Installation in small spaces without linear distances		X					
Irrigation	X	X		X			
Industrial process liquids, sludge, and concrete	X		X				
Mines	X		X				
District measure					X	X	X
Drinking or wastewater measurement	X	X	X				
Tax measures	X	X					
Industrial processes	X		X				
Flow profiling					X	X	X
Leakage detection		X			X		
Building sector	X			X			
Fire-fighting systems	X			X			
Refrigeration systems	X			X			
Pumping stations	X						
Water treatment	X		X				
Verification of flowmeters on site					X	X	X

2 PRODUCT DESCRIPTION

2.1 OPERATING PRINCIPLE

The electromagnetic sensor is used to measure the flow rate of liquids (drinking water, wastewater, beverages, fertilizers, chemical products, and any other liquid) that have an electrical conductivity of at least $5\mu\text{S}/\text{cm}$. Electromagnetic flowmeters are the best solution for measuring the flow rate liquids because of fast response times, great measurement accuracy, and a passage tube that does not present any obstruction to the liquid flow, therefore no pressure drop in the pipe.

Furthermore, since they do not use any moving parts, they require virtually no maintenance.

EUROMAG electromagnetic flowmeters cover a wide variety of applications (e.g., water flowmeters, wastewater flow measurement, fertilizer flow measurement, etc.) and respond to every customer request thanks to the wide range of models.

Meters are available in wafer, flanged, threaded, and insertion versions from DN6 to DN2000 in pressure class up to ANSI900.



In order to perform its measuring function, the sensor must be combined with a converter.

The converters are designed to meet all the needs of modern water management systems through flexible and hybrid electronics, which, depending on the model, offers various electrical power solutions.

At the ends of a conductive fluid that moves with speed v in a magnetic induction field B an electromotive force e is induced and can be expressed as:

$$e = kBDv$$

Where:

- B** B is constant by construction;
- D** is constant and represents the distance between the electrodes **E1** and **E2** (equivalent to the flowmeter diameter);
- v** is the speed of the liquid;
- k** is the calibration constant;

The electromotive force «e» is proportional to the speed «v»

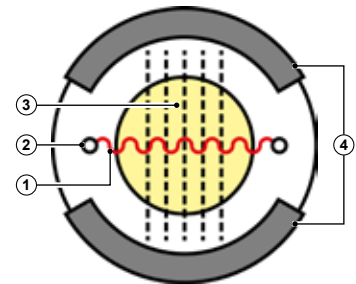

- ① - Electromotive force (proportional to the speed);
- ② - Electrodes;
- ③ - Magnetic field;
- ④ - Coils;

2.1.1 Bidirectional reading

The sensor has a possibility of bidirectional reading (i.e., it is able to read the flow of the liquid in both directions).

By convention, the sensor will output positive values if the liquid flows:

- » in the same direction as the arrow (enters in – and exits in +), the flow is positive, and the display will show a reading without a sign
- » in the opposite direction to that indicated by the arrow (enters in + and exits in -), the flow is negative, and the display will show a reading with a negative sign

		Direct flow -> number without sign
		Reverse flow -> negative number

2.2 AVAILABLE VERSIONS

EUROMAG manufactures its sensors in different versions, each intended for use in different applications, as summarized in the paragraph "1.5 Applications."

The different sensor versions available are shown below.

2.2.1 Flanged sensors

- MUT2200EL – Full Bore
- MUT2300 – Reduced Bore

2.2.2 Wafer sensors







- MUT1000EL - Wafer
- MUT1100J - Wafer in plastic material

2.2.3 Insertion sensors

- MUT1222
- MUT2660
- MUT2770

2.3 TYPES OF INSTALLATION OF THE SENSOR

The sensors in different versions can be connected to the converter in two different ways, namely:

	Flanged Sensors	Wafer Sensors	Insertion Sensors
<p>COMPACT installation: The sensor is connected directly to the related converter.</p>			
<p>SEPARATE installation [remote]: The sensor is connected to the converter by specific power/signal cables.</p>			

3 INSTALLATION

3.1 STORAGE AND MOVING

3.1.1 Storage

i To ensure the correct maintenance of the device while waiting for its installation, it is necessary to comply with the storage provisions below:

- 1) Store the device in a dry place and protected from dust
- 2) Keep away from direct and continued sunlight
- 3) Keep the device in the original packaging until it is used
- 4) Temperature of the storage place: $-40 \div +70 \text{ }^{\circ}\text{C}$ ($-40 \div +158 \text{ }^{\circ}\text{F}$)

3.1.2 Moving

! **CAUTION!** The sensor must be carefully lifted and moved so as not to cause damage to the sensor itself and connection flanges. Below you will find a description of correct and incorrect lifting and moving.

The proper lifting method (for transport and installation) of the sensor is shown in Fig. 2.

The flowmeter must be lifted and transported by properly harnessing the device on the side parts of the flowmeter, making sure that the slings (ropes, bands, etc.) are fixed to the appropriate eyebolts.

! **WARNING:** Do not raise the flowmeter harnessing the converter (Fig. 3)!!

! Do not move the flowmeter with the lifting device if it is not in the original packaging (Fig. 4) or without adequate support that ensures the required stability.

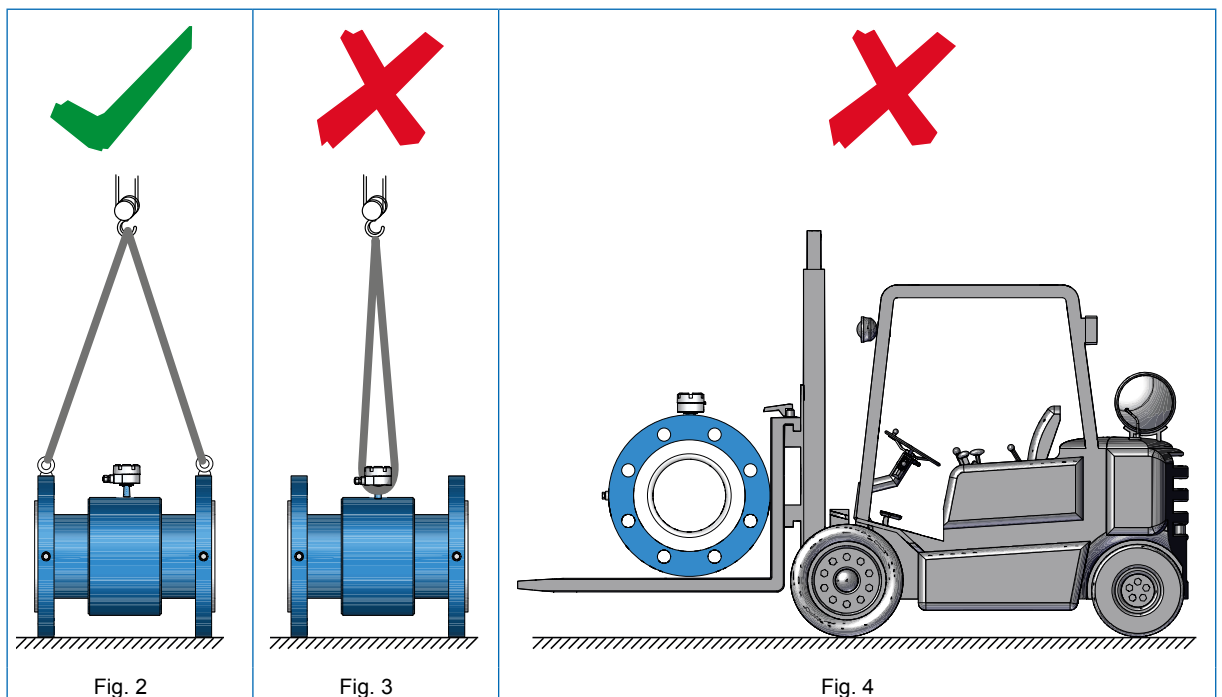

3.2 GENERAL INSTALLATION REQUIREMENTS

IMPORTANT NOTE! THE SENSOR MUST ALWAYS BE COMPLETELY FULL OF LIQUID!



Fig. 5 The pipe must always be completely full of liquid

3.2.1 Vibrations

- DO NOT expose the flowmeter to vibrations and/or movements that could affect its performance and duration.

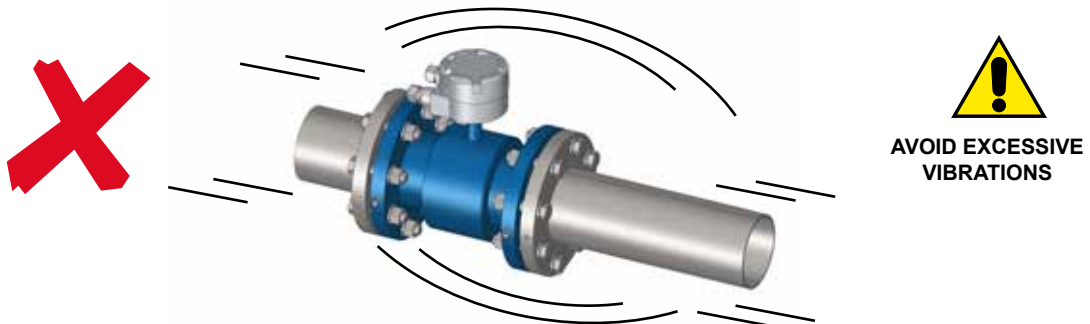

Fig. 6 Avoid vibrations

- Install a suitable anti-vibration protection if vibrations occur.



Fig. 7 Installation with anti-vibration protections

3.2.2 Magnetic fields

- AVOID exposing the flowmeter to strong or nearby magnetic fields.



Fig. 8 Avoid magnetic fields

3.2.3 Negative pressure

- i** Avoid vacuum conditions in the pipe. These can damage the coating of the flowmeter and move the electrodes from their correct position.

3.2.4 Protection from direct sunlight

- Protect the flowmeter if exposed to direct sunlight.

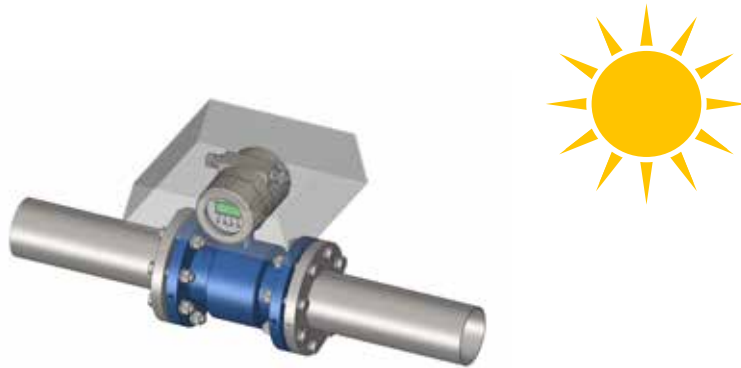

Fig. 9 Avoid direct exposure to sunlight

3.2.5 Operating temperatures

- For normal and efficient operating of the flowmeter:
 - » The room temperature must be limited within the range of $(-25 \div +60) ^\circ\text{C}$, $(-13 \div +140) ^\circ\text{F}$.

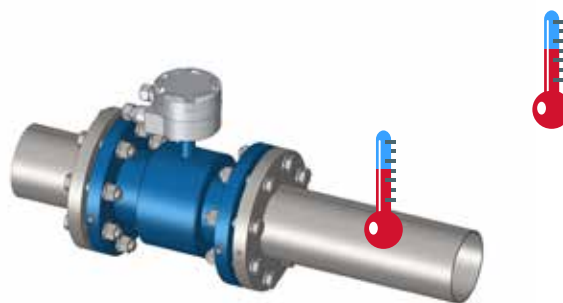

Fig. 10 Environment and fluid temperature limits

	°C		°F	
	Min.	Max.	Min.	Max.
Coating in EBONITE	-40	+80	-40	+176
Coating in PTFE (remote)	-40	+130	-40	+266
Coating in PTFE (compact)	-40	+80	-40	+176
Coating in PTFE (separate high temperature)	-40	+180	-40	+356
MUT1100J	0	+80	32	+176
INSERZIONI	-20	+80	-4	+176

3.3 INSTALLATION CONDITIONS

3.3.1 Positioning in relation to the plant

- To ensure optimal working conditions, the flowmeter must be installed correctly inside the system. Correct and incorrect installation positions are described and illustrated below.**

The flowmeter must remain below the hypothetical blue line (piezometric level line), which connects the two levels of fluid to be measured (Fig. 11).

- NOTE: Avoid placing the flowmeter above the piezometric level line (Fig. 12).**

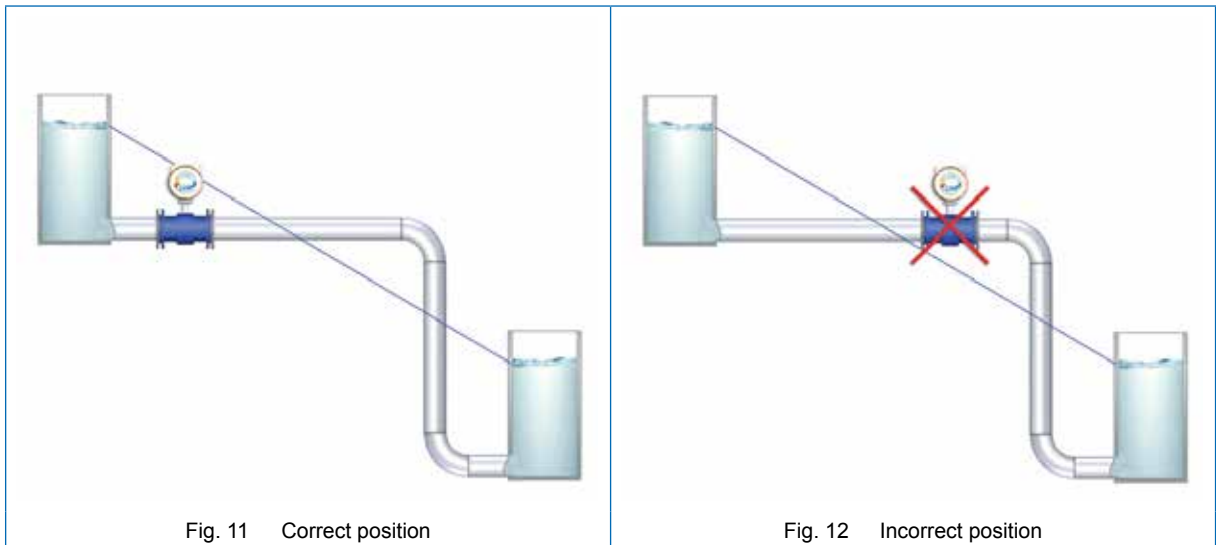

3.3.2 Important guidelines for correct installation

- The junction box on the sensor is designed to have the IP68 protection degree only when properly closed and tightened. The manufacturer does not assume any responsibility for an improper closing by third parties.**

For correct working conditions, please follow the important guidelines shown in the following figures. Improper installation may result in an inaccurate measurement.

For partially filled pipes or with downward flow and free exit, the flowmeter should be placed in a U-shaped tube (see Fig. 13).

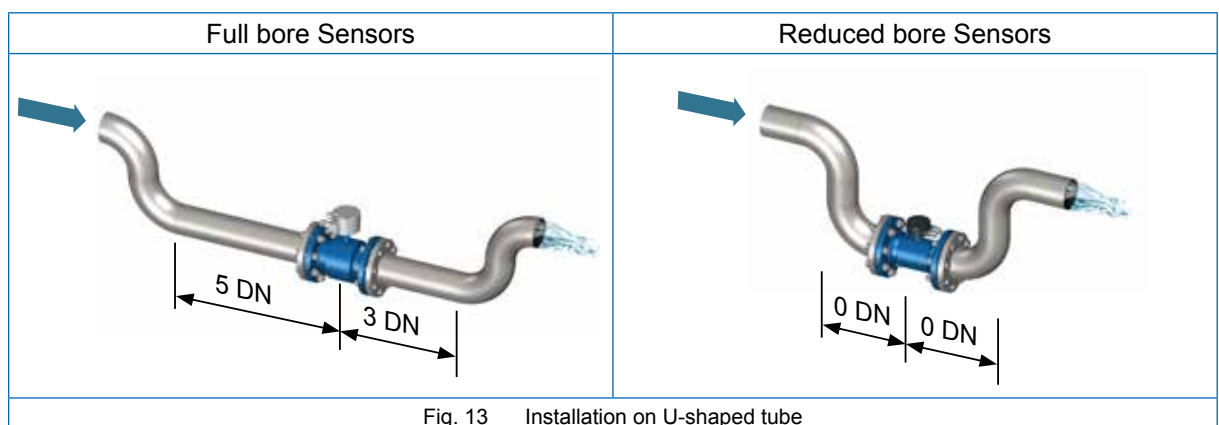

Fig. 13 Installation on U-shaped tube

Insertion sensors

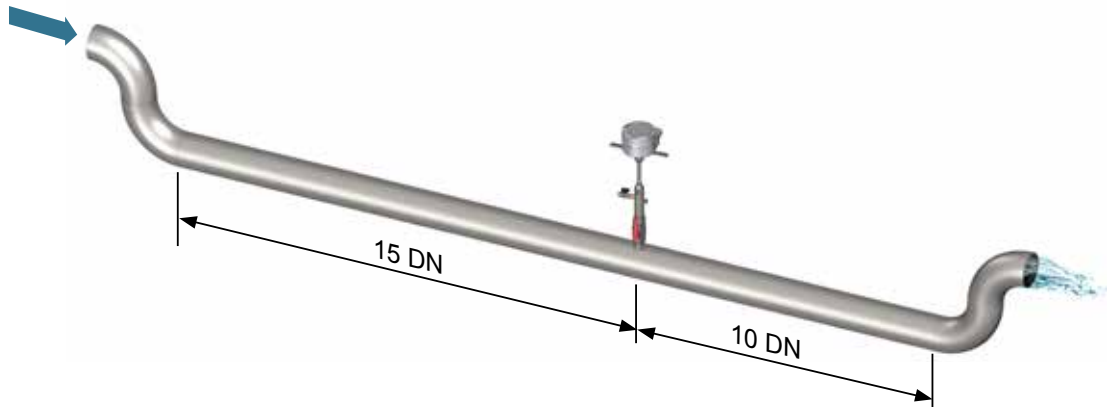

Fig. 14 Installation on U-shaped tube

"T" connection downstream of the flowmeter

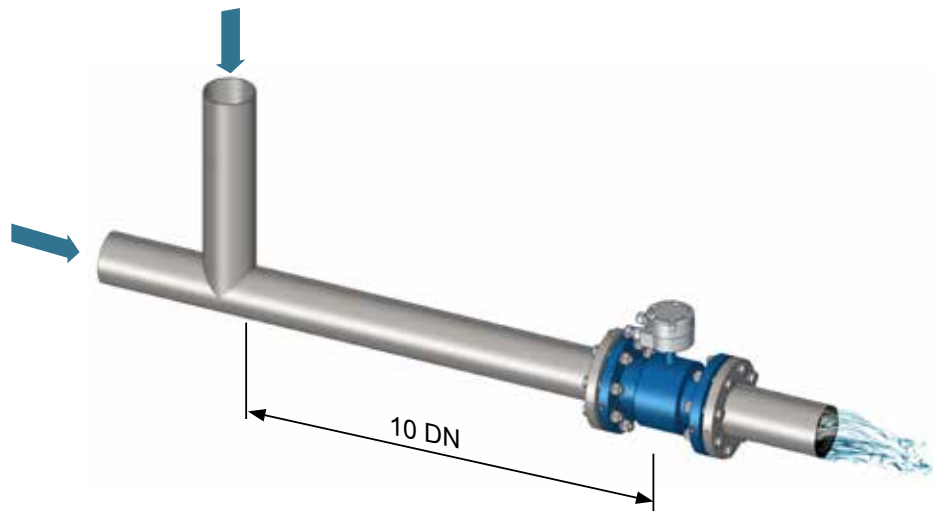

Fig. 15 Installation on U-shaped tube

Three-dimensional curves

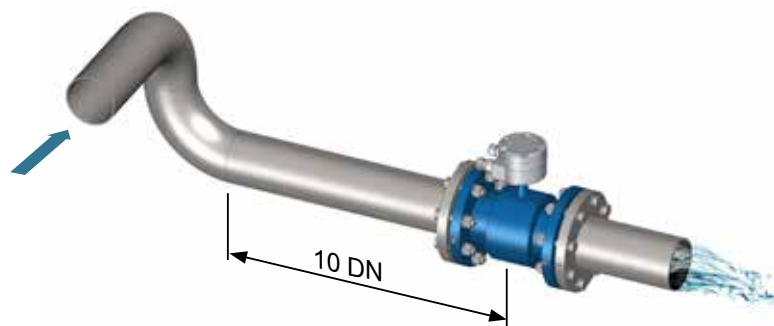
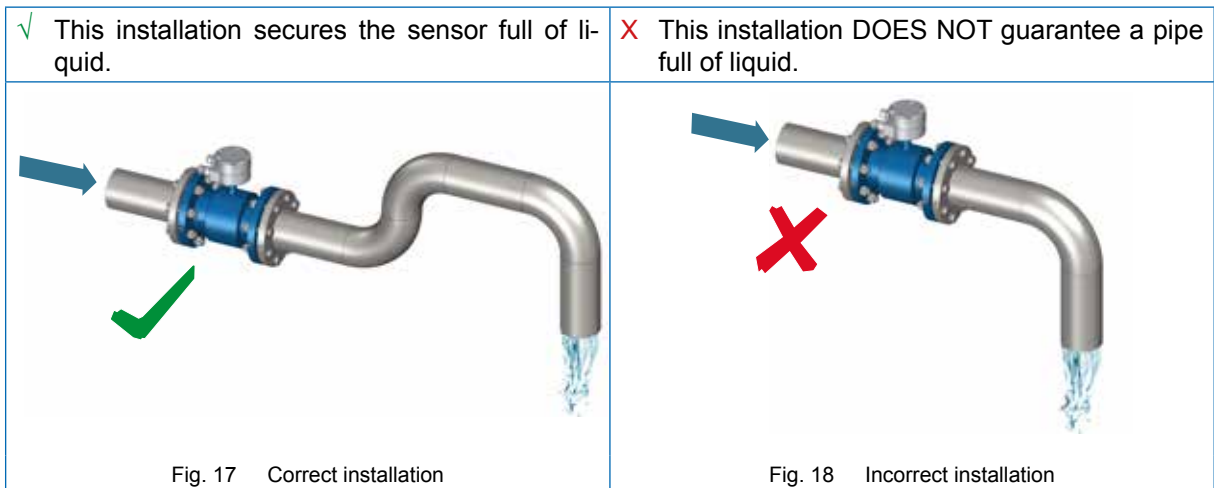

Fig. 16 Installation near three-dimensional bends

IMPORTANT NOTE: THE SENSOR MUST ALWAYS BE COMPLETELY FULL OF LIQUID!

To ensure that the sensor is always completely filled with liquid, it is important to install it in the correct position (✓) and avoid all possible incorrect positions (✗).



We recommend installing the sensor on a vertical/sloped pipe with an upward flow direction (Fig. 19) to minimize the wear and deposits in the sensor. Avoid the installation on vertical pipes with free exit (Fig. 20).

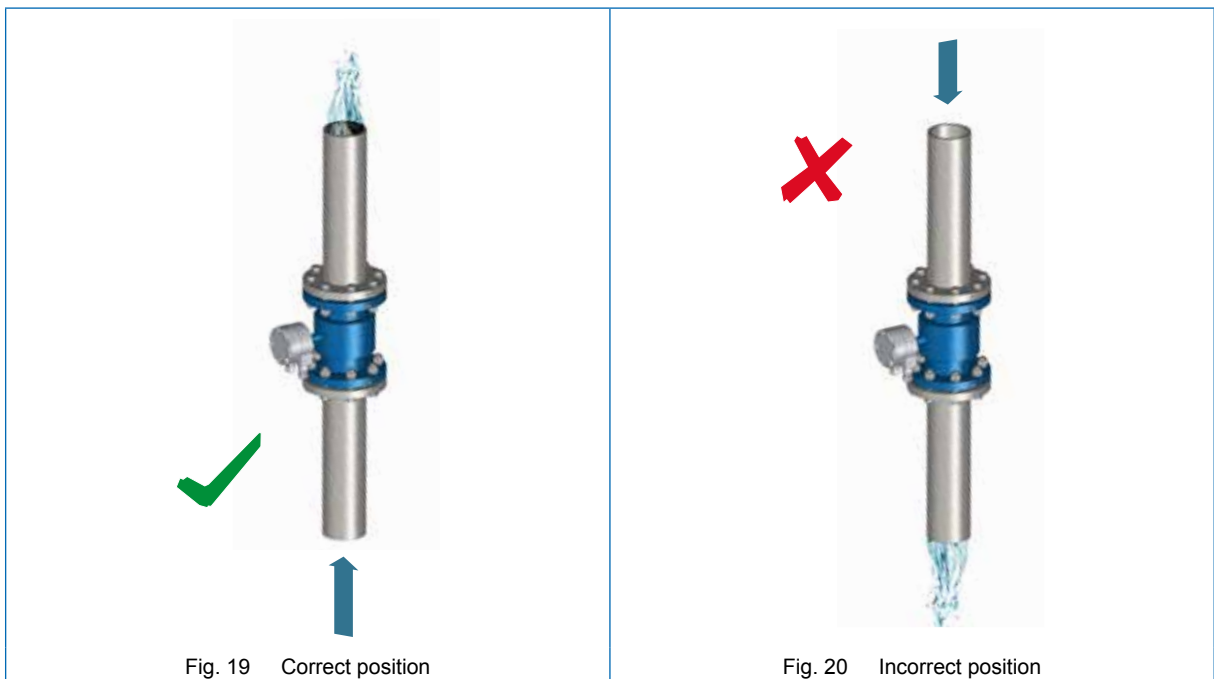

✓ The position on the left secures the sensor full of liquid. ✗ Central and right positions DO NOT guarantee a pipe full of liquid.



Fig. 21 Correct (LH) and incorrect installation (central and RH)

We recommend installing gate valves downstream of the meter.



Fig. 22 Gate valves installation

✗ In order to avoid a vacuum, always install the sensor downstream of the pump and NEVER upstream.

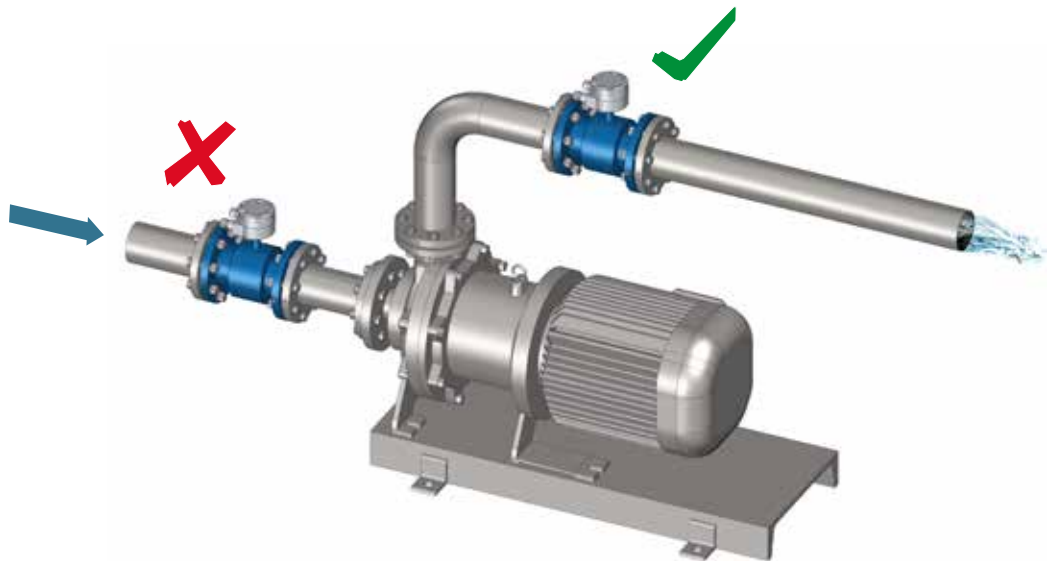
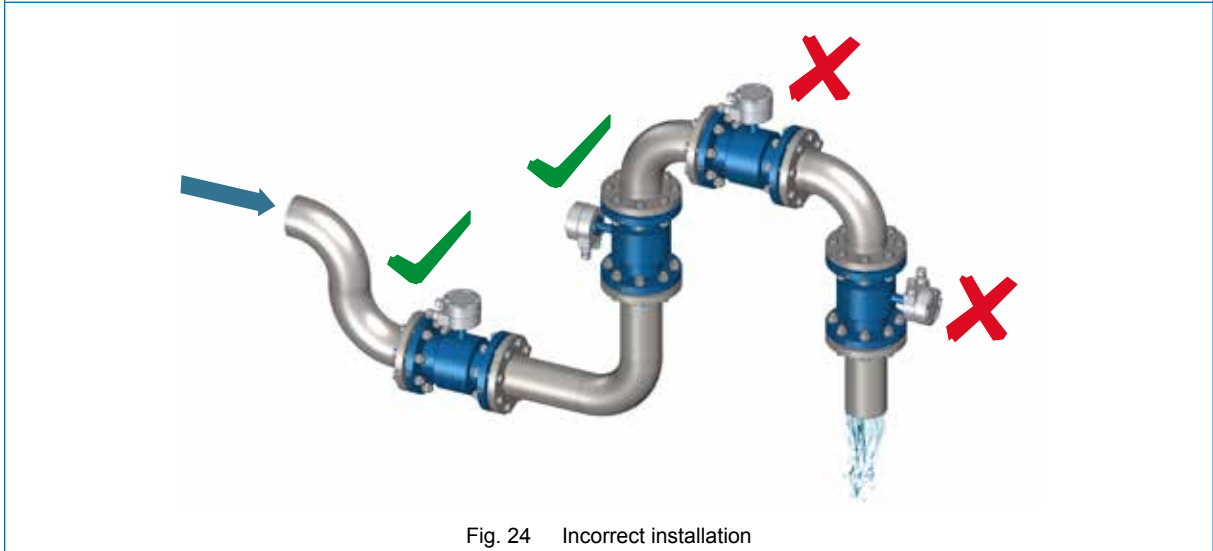

Fig. 23 Avoid negative pressure

✗ DO NOT install the sensor on vertical pipes with a free outlet or at the highest point of the pipe system.



3.4 INSTALLATION

3.4.1 Important instructions on installation

In case of inadequate distance between the sensor and the pipe, use elastic pipe fittings (Fig. 25). Do not try to move the pipe closer to the sensor by tightening the bolts (Fig. 26).

i Do not try to move the pipe closer to the sensor by tightening the bolts.

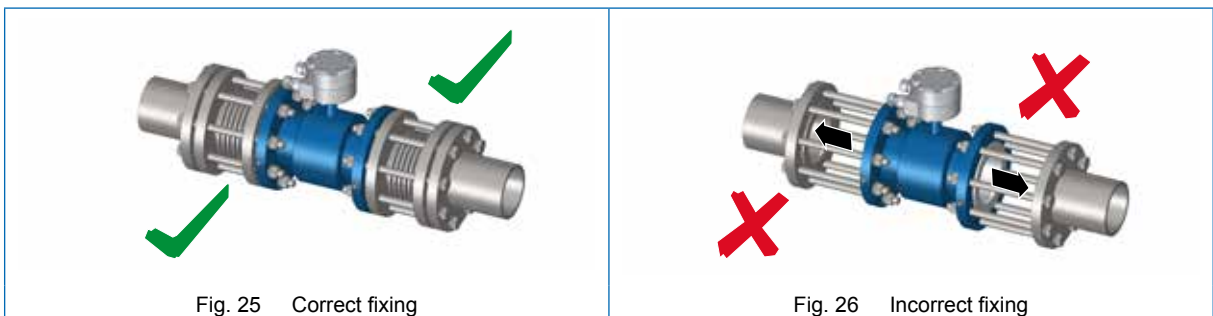

Also avoid the following positions (*):

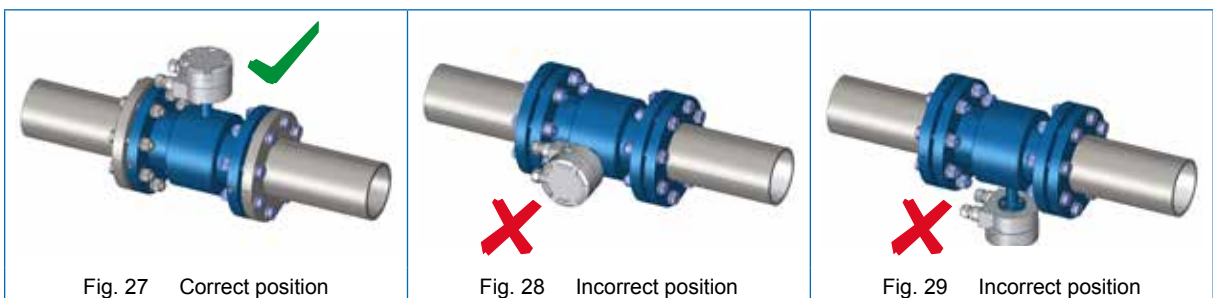

i (*) Note: Insertion meters can also be installed horizontally.

Maximum allowable deviation of the pipe flange faces is 0.5 mm.

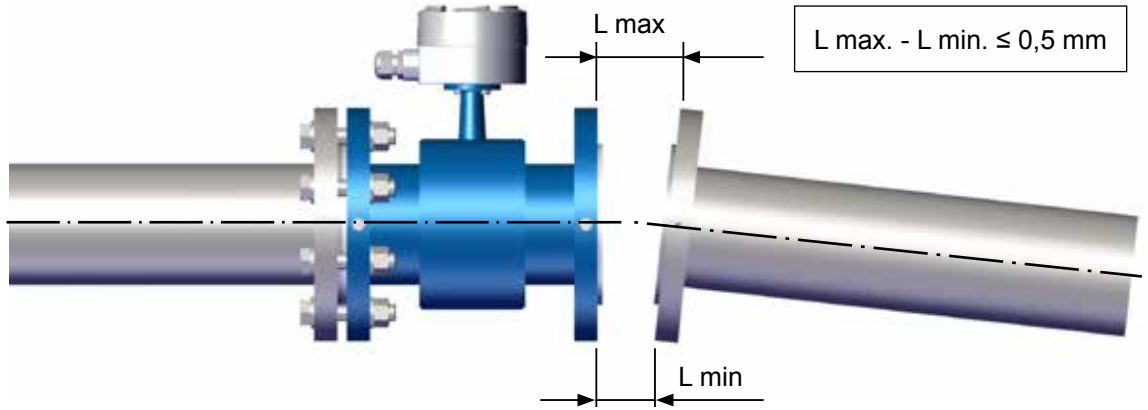

Fig. 30 Maximum allowable deviation

3.4.2 Sensor support

✗ DO NOT USE the sensor as a support for the pipe.

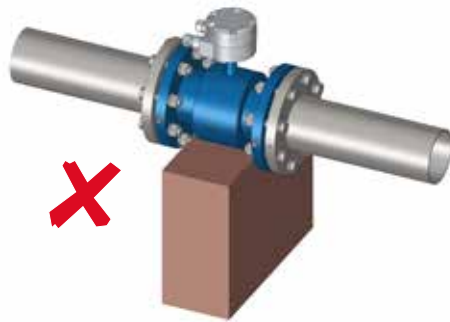

Fig. 31 Incorrect installation

✓ The pipe must be the support for the flowmeter.

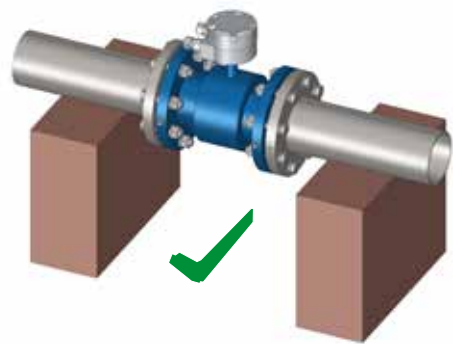

Fig. 32 Correct installation

3.4.3 Tightening torque

- Flanged sensors

Standard bolts must be lubricated well and tightened evenly around the gasket. If the bolts are over-tightened, leakage or damage to the flowmeter or piping may occur.

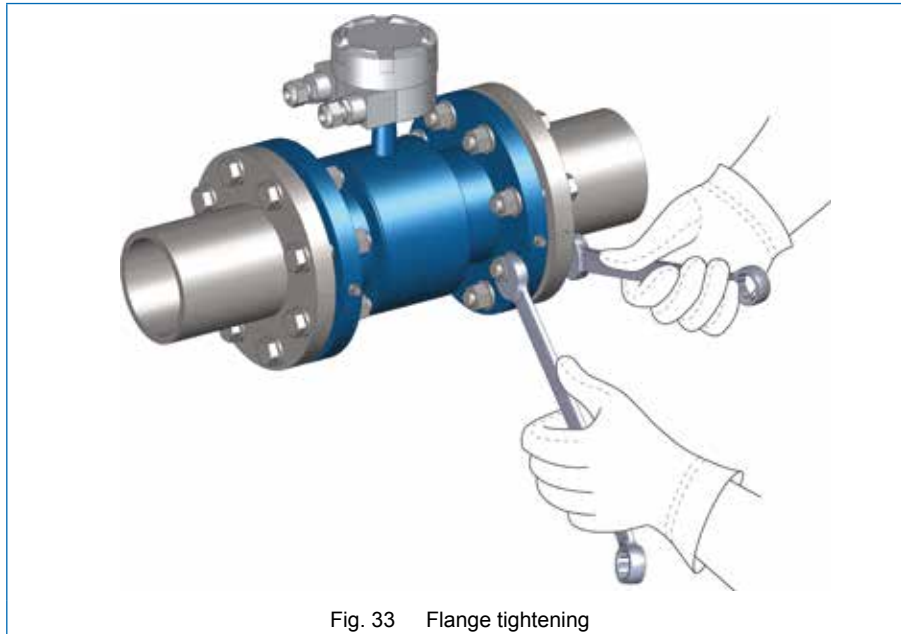

Fig. 33 Flange tightening

Carefully follow the instructions given in the diagrams. Check the correct centering of the sensor before you tighten the flanges and proceed following the steps described here.

- Step 1. \approx 50% of the maximum tightening torque
- Step 2. \approx 80% of the maximum tightening torque
- Step 3. 100% of the maximum tightening torque given in the diagram

All the values are theoretical and have been calculated for optimal conditions and with the use of carbon steel flanges.

- Wafer Sensors

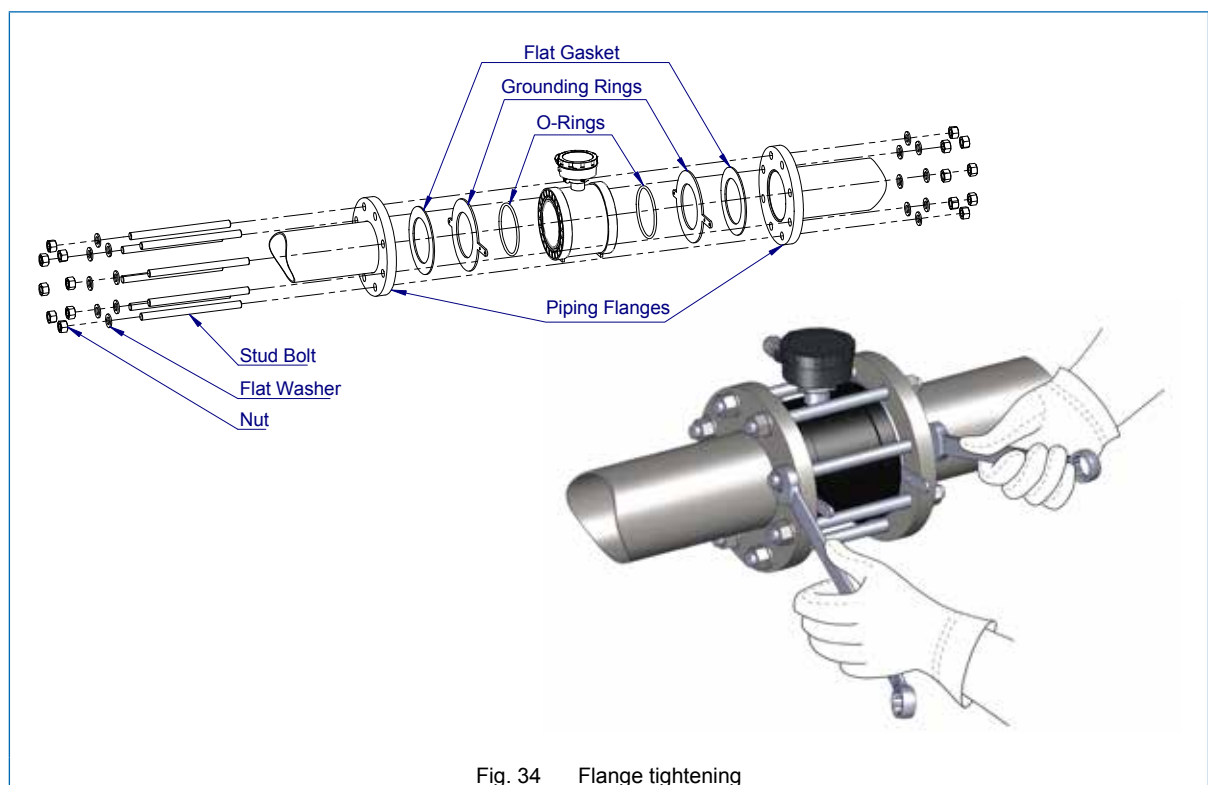

Fig. 34 Flange tightening

DN	PN	BULLONI	Maximum tightening torque [Nm]				
			MUT2200EL		MUT1000EL		MUT110J
			PTFE	Ebanite	PTFE	Ebanite	OR NBR
15	40	4xM12	10	6	-	-	-
20	40	4xM12	16	10	-	-	-
25	40	4xM16	20	12	15	-	-
32	40	4xM16	35	20	25	-	-
40	40	4xM16	45	25	30	-	25
50	40	4xM16	55	30	40	-	35
65	40	8xM16	38	25	30	-	25
80	40	8xM16	45	25	35	-	30
100	16	8xM16	45	25	35	-	30
125	16	8xM16	55	40	45	32	-
150	16	8xM20	70	50	60	45	50
200	10	8xM20	85	70	-	55	-
200	16	12xM20	70	45	-	35	-
250	10	12xM20	80	65	-	50	-
250	16	12xM24	115	80	-	65	-
300	10	12xM20	90	75	-	60	-
300	16	12xM24	145	105	-	85	-
350	10	16xM20	100	75	-	-	-
400	10	16xM24	140	105	-	-	-
450	10	20xM24	-	95	-	-	-
500	10	20xM24	-	110	-	-	-
600	10	20xM27	-	140	-	-	-
700	10	20xM27	-	160	-	-	-
800	10	24xM30	-	220	-	-	-
900	10	28xM30	-	205	-	-	-
1000	10	28xM35	-	260	-	-	-

3.4.4 Underground installations

The remote sensor is protected by IP68/ NEMA 6P and can be positioned underground. We recommend the use of gravel for at least 300mm (12 inches) around the sensor. This provides drainage and prevents dirt solidification on the sensor. In addition, it facilitates the location of the same if new excavations are required. Before covering the gravel with earth, we recommend using electrical cable identification tape above the gravel itself. The remote sensor cable should pass through a plastic conduit.

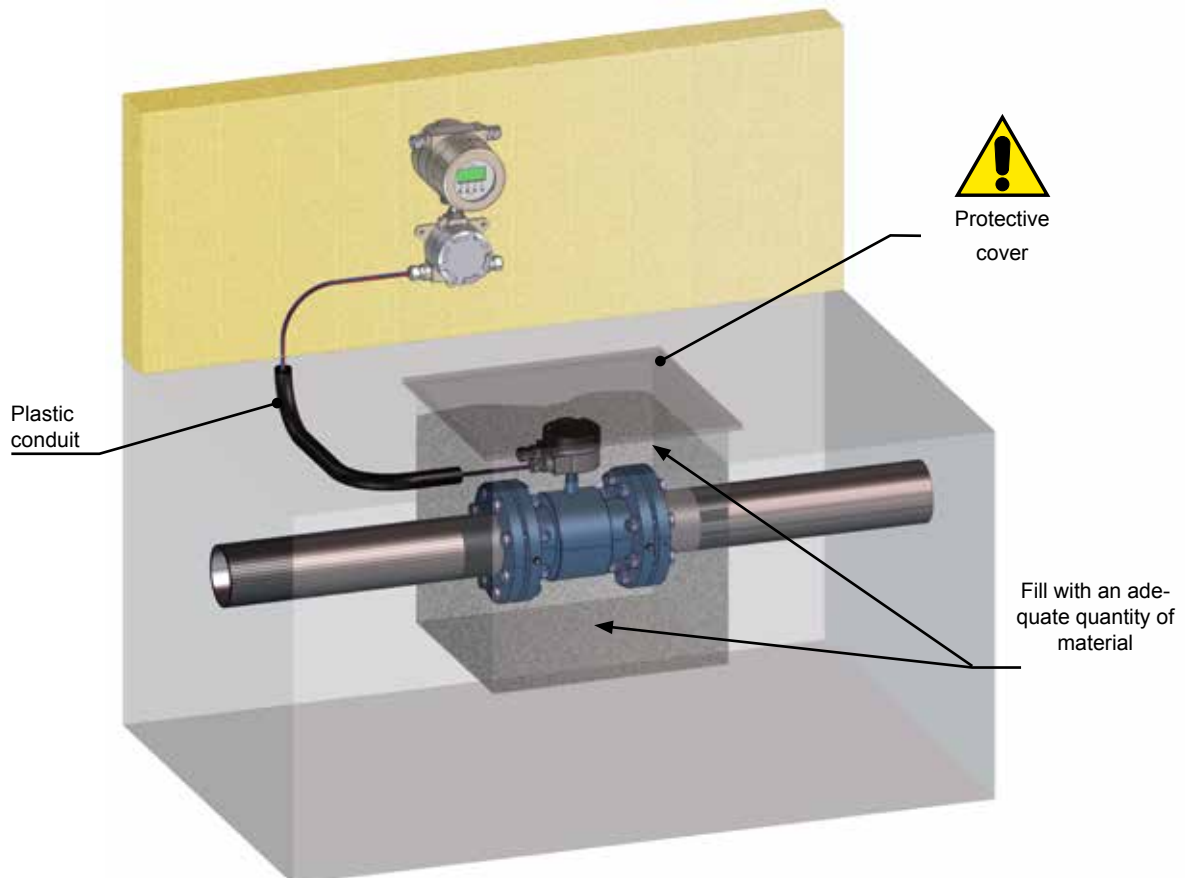

Fig. 35 Underground installation

3.5 HOW TO AVOID AIR POCKETS IN THE PIPELINES

This paragraph is intended to help the designers and users of electromagnetic flowmeters to create the best installation layout that guarantees optimum performance of the meter, taking into particular consideration the problem of the presence of air pockets in the pipe.

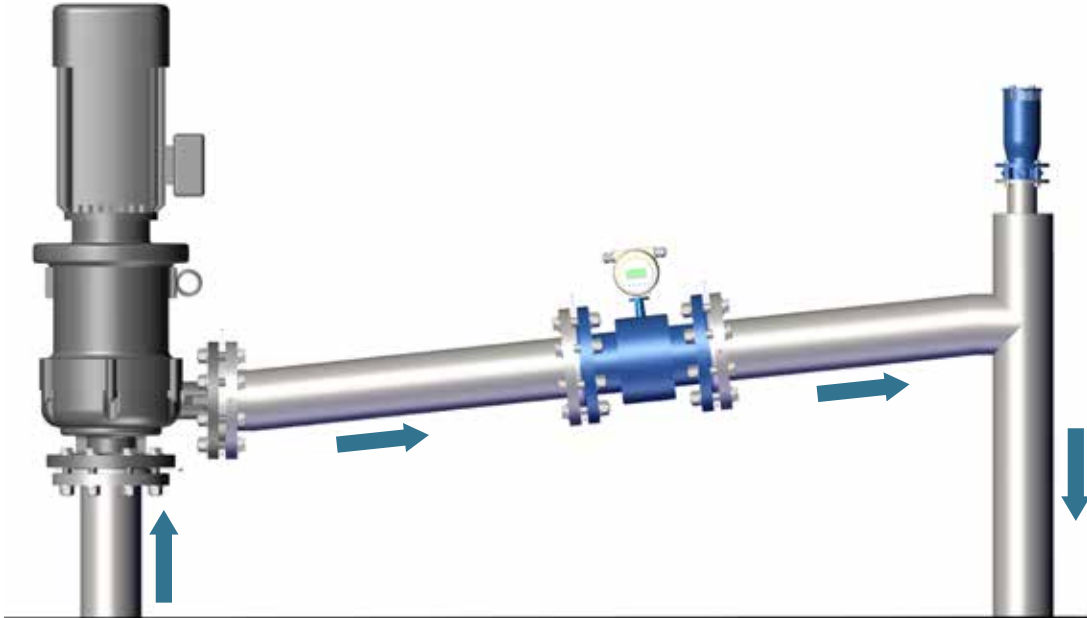

Fig. 36 Pumping stations with flowmeters and vent valves

i What are the problems caused by the air pockets entrapped in any flowmeter?

The presence of air pockets can cause serious reading errors or strong instability. In this case, the flowmeter could go into Error mode (see the related converter manual).

i How are air pockets removed, or moved away from the flowmeter?

The air pocket inside a pipe always moves toward the top of the pipe, and it is assumed that the air will always move if the flow passes along a horizontal pipe, but this is not the case. Instead, a specific water speed is required to move the air; the greater the diameter of the pipe, the higher the airspeed is required to move it away from the flowmeter.

Typically, most installations of flowmeters are simply sized on the diameter of the tube or on the flow rate in the pipe, which means that the speed is often less than 0.5 m/s, which can be very problematic if the air pockets occur.

As an example in a pipe with zero gradients, these are the specific water speeds necessary to move away the air pockets detected in the tube:

- DN50 → 0.4 m/s
- DN150 → 0.7 m/s
- DN300 → 1 m/s
- DN600 → 1.5 m/s



Fig. 37 Air pockets inside the pipe

The greater the diameter of the pipe, the higher the speed of the liquid will be required to move the air pockets away from the flowmeter.

It is also important to understand what kind of effect the water pressure has on the nature of the air pocket inside the pipe. The lower the pressure in the tube, the greater the size of the air pocket is, and the greater the effect it will have on the performance of the flowmeter. By increasing the pressure in the duct, the air pocket will compress, causing fewer problems.

This can be achieved by installing pressure control valves after the flowmeter to maintain constant pressure in any situation.

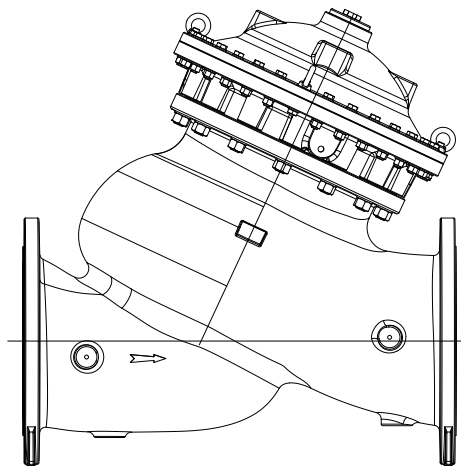

Fig. 38 Example of pressure control valves

One solution is to install the flowmeter on a pipe with an increasing slope so that the entrapped air pocket will move to the highest point. Then, through special vent valves, the air will be released from the pipe, maximizing the system capacity.



Fig. 39 Pipe with an increasing slope for application of vent valves

A minimum slope in an ascending flow of 1: 500 or higher is recommended in order to stimulate the entrapped air pocket to move away from the meter.

Drawings are made with an exaggerated slope for greater clarity

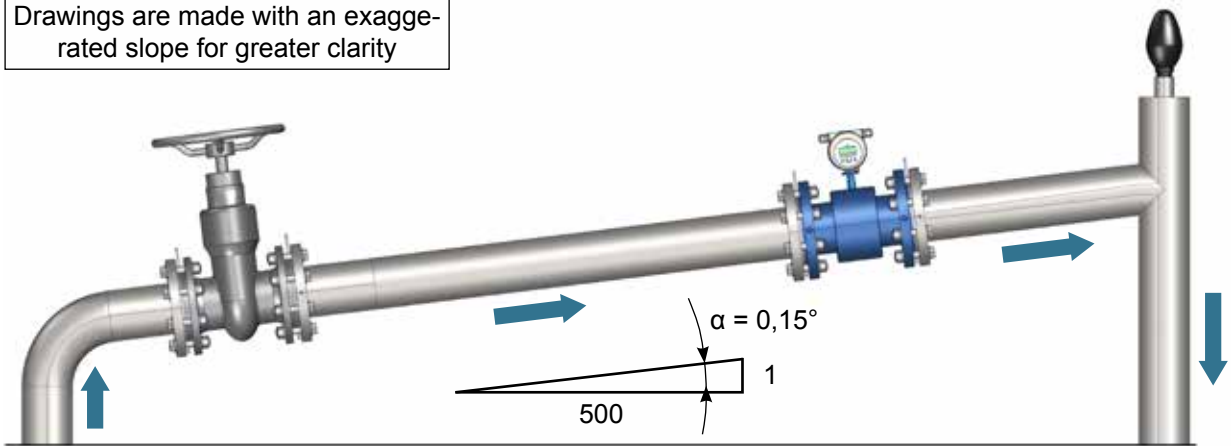

Fig. 40 Flowmeter with slight ascending slope with air vent at the top

A second solution is to mount the flowmeter vertically with an upward flow stream, which ensures that the air always moves quickly past the meter.

i Importance of air vent valves

The general principle of each installation is to ensure that the device is always full of water; however, this is not always possible since a part of the network could drain when the pumps are turned off.

It is, therefore, essential to ensure that the design incorporates a properly designed and sized air vent valve to release the air when the pump starts, making sure that the meter immediately starts reading.

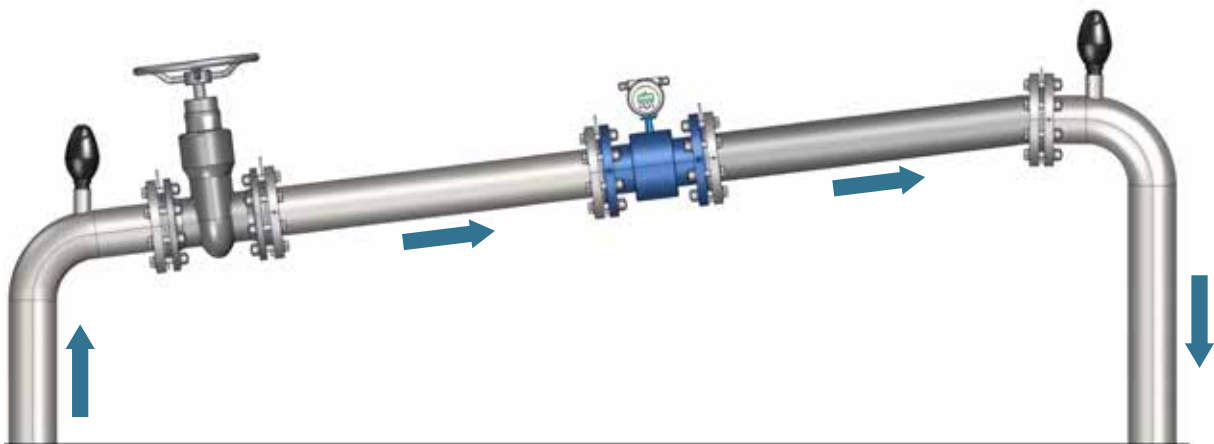

Fig. 41

The design of the vent valve is essential to ensure that the entrapped air pockets are released. Pneumatic valves or vacuum switches should be avoided. Instead, it is preferable to use combined pneumatic valves that incorporate an automatic orifice, as well as a large kinetic orifice. These valves ensure that the largest volumes of air are released quickly and effectively while filling the pipe.

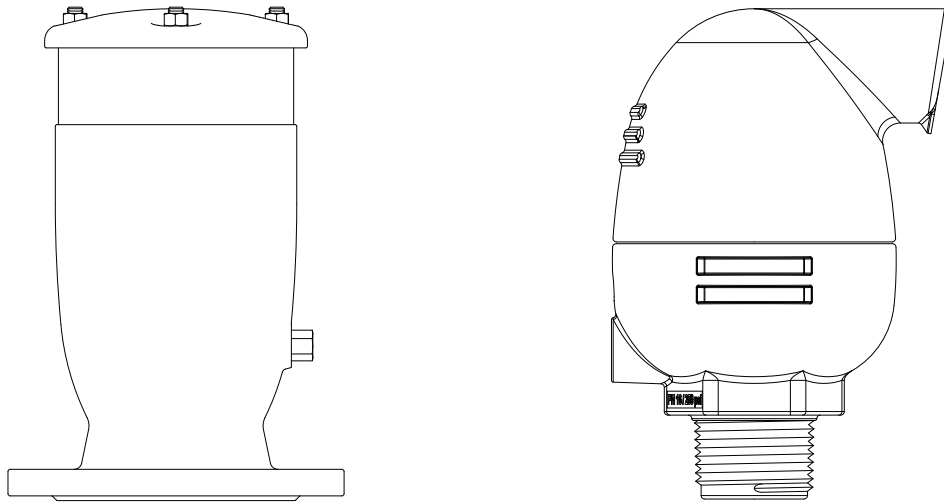
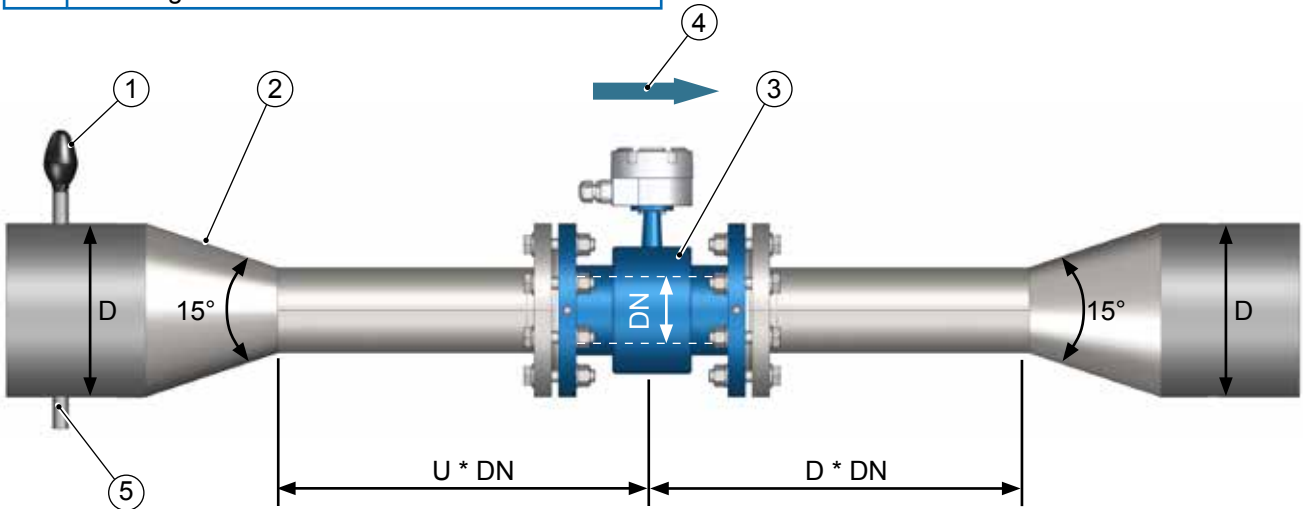

Fig. 42 Typical combined air vent valve, designed with automatic and kinetic air release functions

3.6 INSTRUCTIONS FOR DIAMETER REDUCTION

i In the case of diameter reduction, please refer to the indications shown in the figure below.

REFERENCES	
1	Vent
2	Recommended maximum vertex angle: 15°
3	Flow rate meter
4	Flow
5	Discharge



Flowmeter type	U	D
Full Bore	5	3
Reduced Bore	0	0
Insertion	15	10

Fig. 43 Installation on pipes with diameter reduction



i The diameter reduction introduces a pressure drop in the system. Pay attention, especially when the flow rates are high and if the section reduction is applied simultaneously with the use of reduced section meters. In the case of low pressures, the section reduction could also lead to cavitation formation, especially if the meter has a reduced section; this condition must be absolutely avoided.

4 POTENTIAL EQUALIZATION

4.1 GENERAL INDICATIONS

The sensor must be grounded, as shown in the figures below, using the cables with a minimum section of 2.5 mm² (recommended: 4 mm²). This will assure the potential bonding, noise reduction, and, in the case of a metal pipe, it will guarantee electrical continuity.

Liquid potential equalization or grounding is obtained with the built-in grounding electrode (the so-called 3rd electrode). The 3rd electrode electrically connects the liquid to the device in order to provide a stable and accurate measurement

-  **The sensor must always be grounded! An incorrect grounding may lead to an incorrect measurement.**
-  **GROUNDING CABLE: Minimum section 2.5 mm² (recommended: 4 mm²), grounding screws M5. Recommended ground resistant value is $\leq 5\Omega$**
-  **The flowmeter is equipped with a grounding electrode (third electrode). In the case of plastic or coated pipes, we recommended the use of ground rings.**

Earthing rings can be used on both ends of the pipes. The earthing rings are indispensable in the case of plastic or coated metal pipes to ensure good potential compensation. Earthing rings are supplied on request. Refer to the images on the following pages for more information.

SEPARATE version grounding connection

The sensor must be earthed using the appropriate ground screw placed on the separation box.

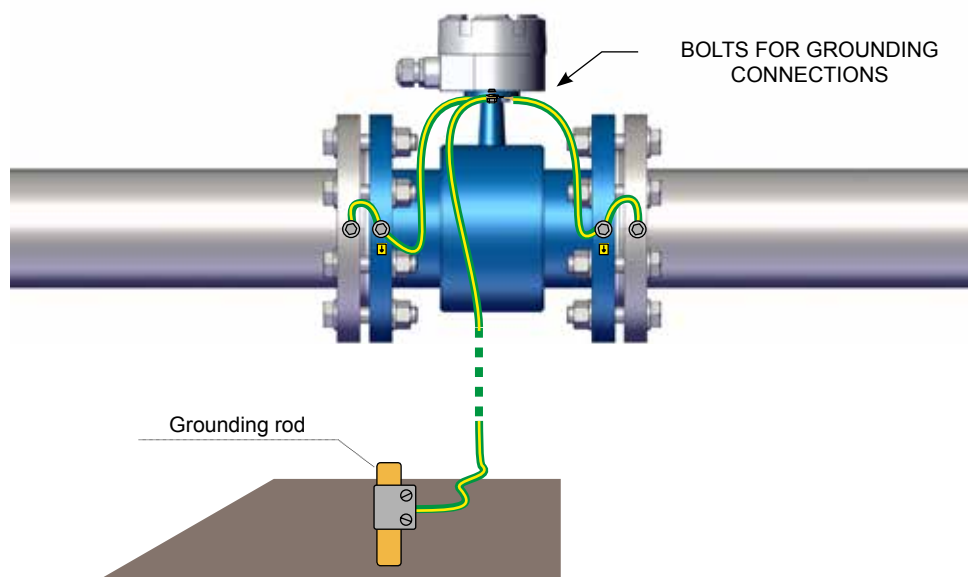

Fig. 44 Separate version grounding connection

Compact version grounding connections

The sensor must be earthed using the appropriate ground screw placed on the converter casing

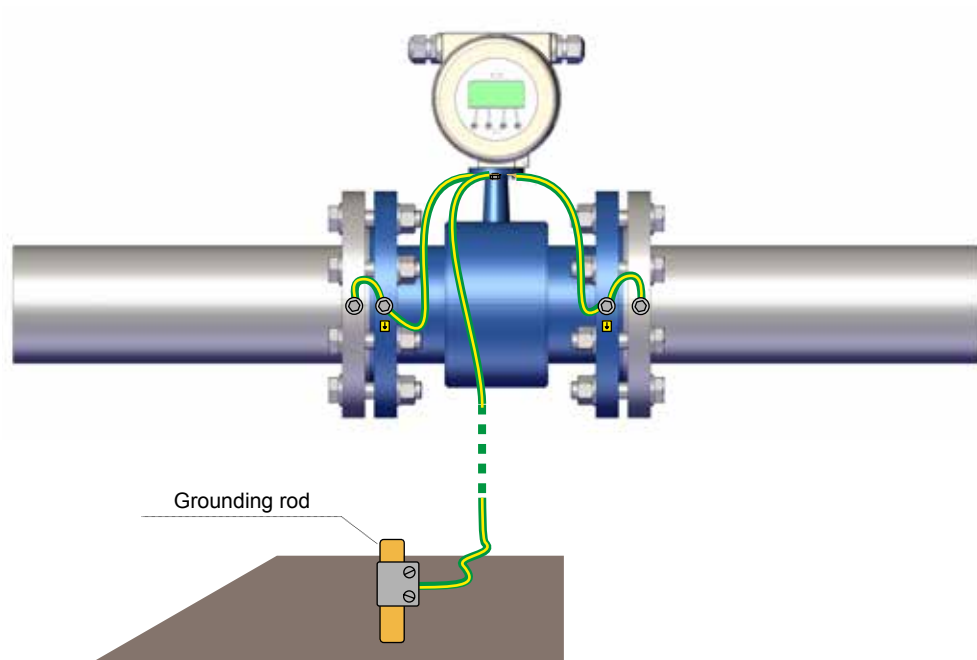

Fig. 45 Compact version grounding connection

4.2 PLASTIC PIPES

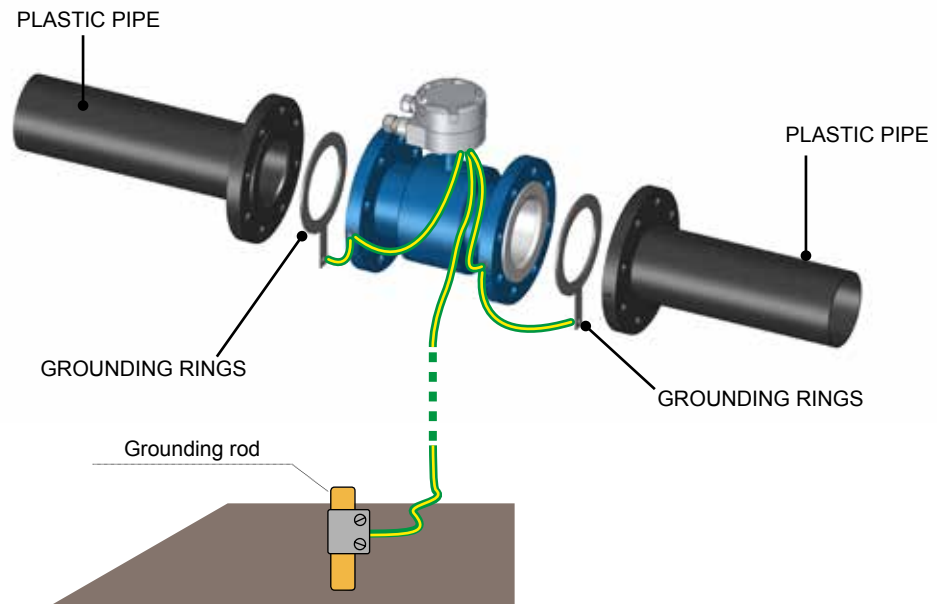

Fig. 46 Application of grounding rings

4.3 METAL PIPES

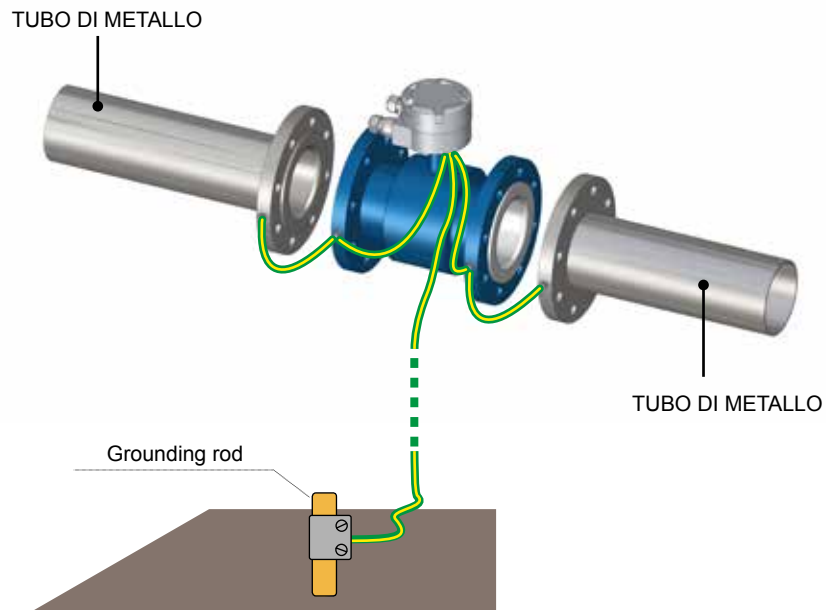

Fig. 47 Grounding of sensor on metal pipes



In the case of metal pipes with an insulating coating, follow the instructions for plastic pipes.

4.4 METAL PIPES WITH INSULATING ADAPTERS

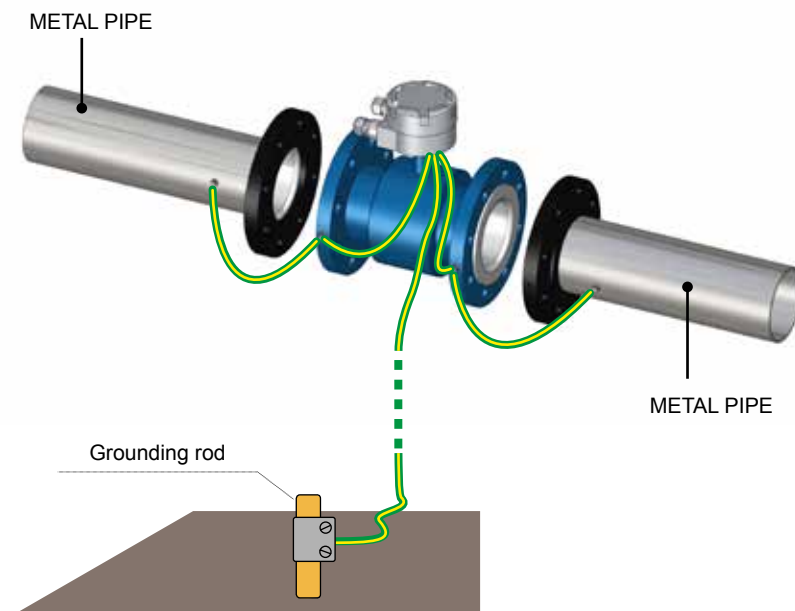

Fig. 48 Grounding of the sensor on metal pipes with adapters

4.5 METAL AND PLASTIC PIPES

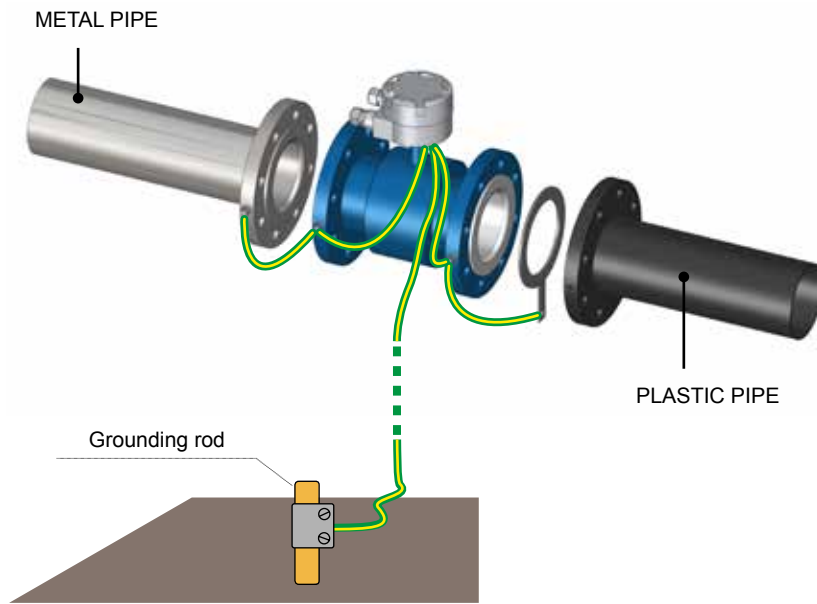
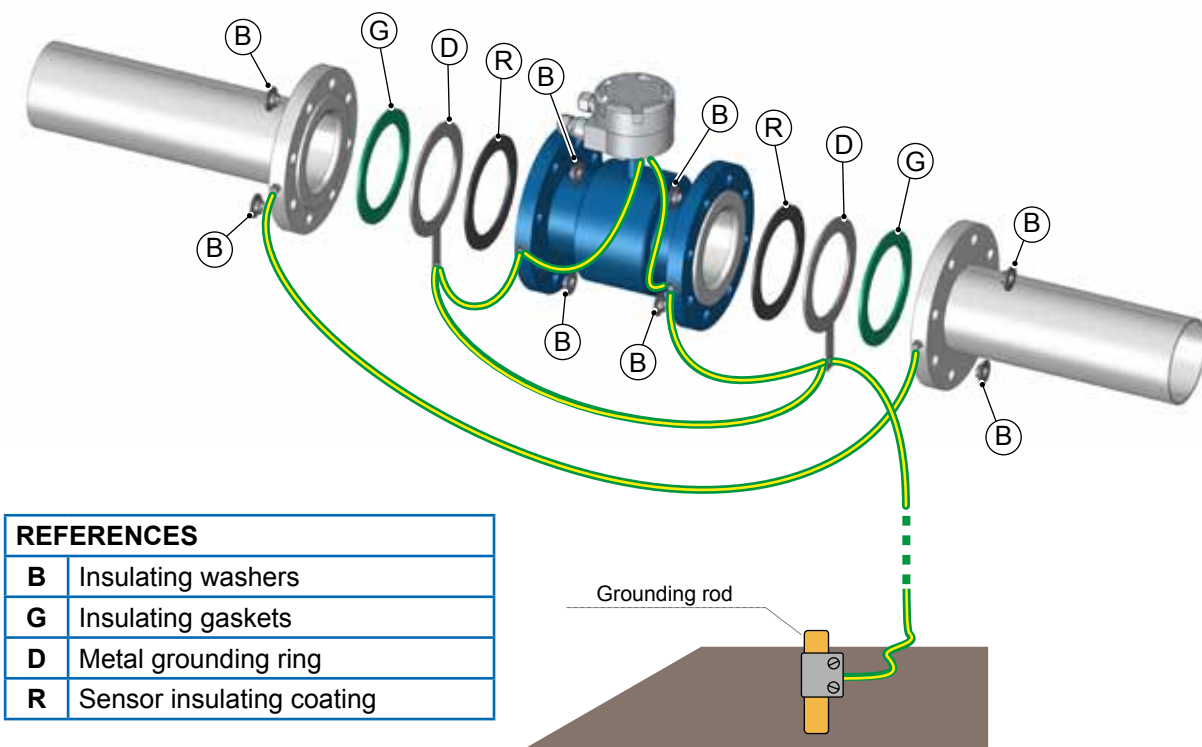

Fig. 49 Grounding of the sensor on metal and plastic pipes (with grounding rings)

4.6 PIPES EQUIPPED WITH CATHODIC PROTECTION

Particular attention must be paid when installing the product in the pipeline with cathodic protection. Isolate it from the pipeline by installing isolation bushings and washers on the bolts of the flange and connect a wire between the pipes, large enough to handle the cathodic current and the environmental effect. Use the grounding rings on both ends (see Fig. 50).





REFERENCES	
B	Insulating washers
G	Insulating gaskets
D	Metal grounding ring
R	Sensor insulating coating

Fig. 50 Grounding of the sensor on protected cathodic pipes

5 ELECTRICAL CONNECTION

5.1 SEPARATE VERSION SENSOR CONNECTION

-  **All operations on the electrical connections must be carried out if the instrument is disconnected from the mains and/or from the battery!**
-  **All operations performed on the electrical junction box or the electrical components of the device must be carried out by duly trained and specialized personnel.**

The sensor is supplied with cables connected and resin coated in the separation box unless otherwise requested by the customer.

The following diagrams, for the connection of the separation cables between sensor and converter, may vary according to the type of converter; therefore, follow the indications given in the relevant documentation.

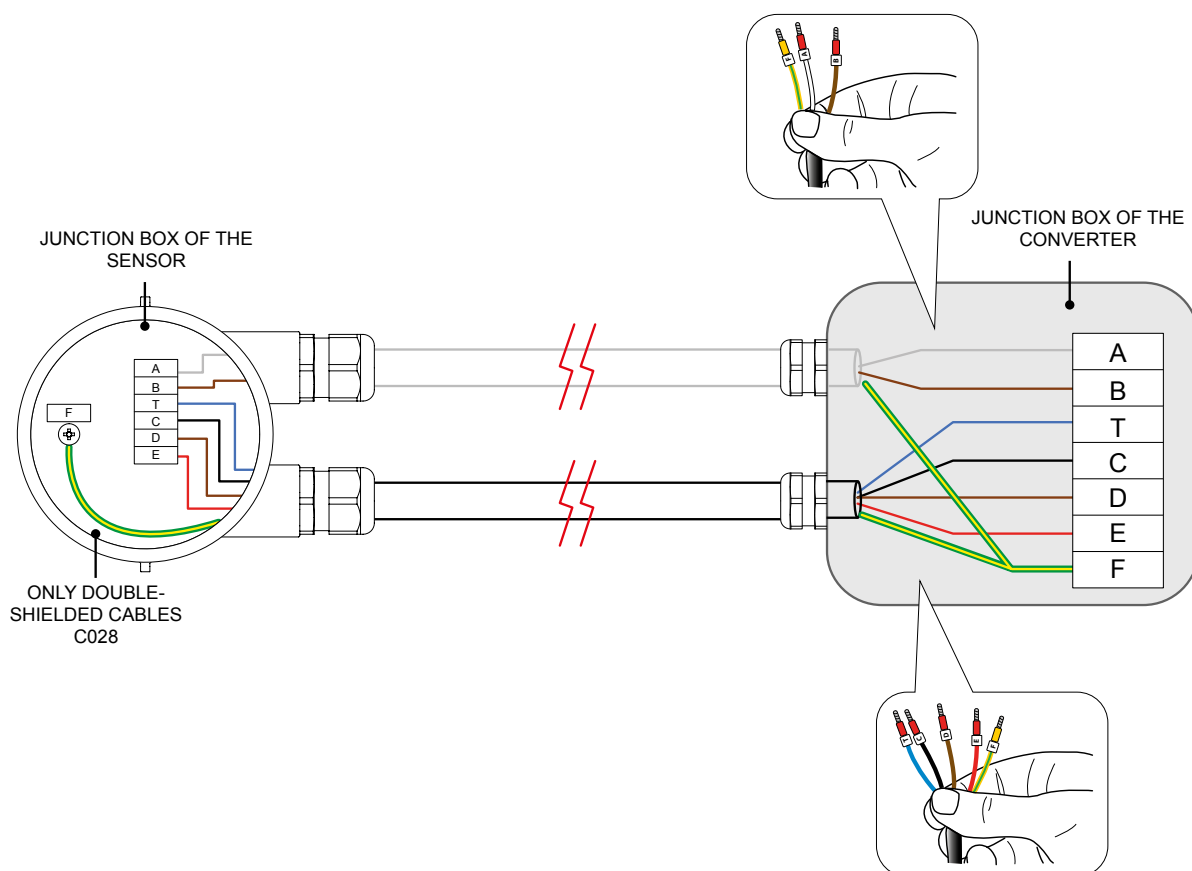





Fig. 51

-  **Info:** If cables in the coil are used, always use the ferrules for the connections in the terminal board and adequately insulate the shields.
-  **Info:** use only cables supplied by Euromag International.
-  **ATTENTION:** After making all the necessary connections, make sure to properly tighten the cable glands and the cover, in order to protect the insulation of the cables and the electrical/electronic boards from humidity and water in case the converter is installed outdoors. Refer to the manual of the relative converter for more information.

5.2 ELECTRICAL DIAGRAMS

5.2.1 Connection with standard single-shielded electrode cable

The shields must ONLY be connected on the converter side.

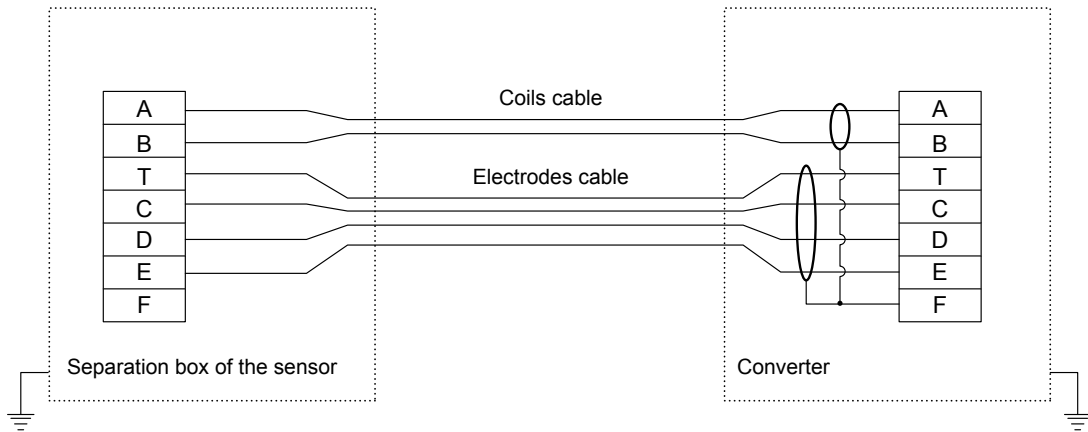

Fig. 52 Standard single-shielded cables - C022

5.2.2 Connection with standard double-shielded electrode cable

The shield of the coil cable must be connected ONLY on the converter side, as well as the INTERNAL shield of the electrode cable. The EXTERNAL shield of the electrode cable must be connected to the case on the earthing point of the separation box of the sensor.

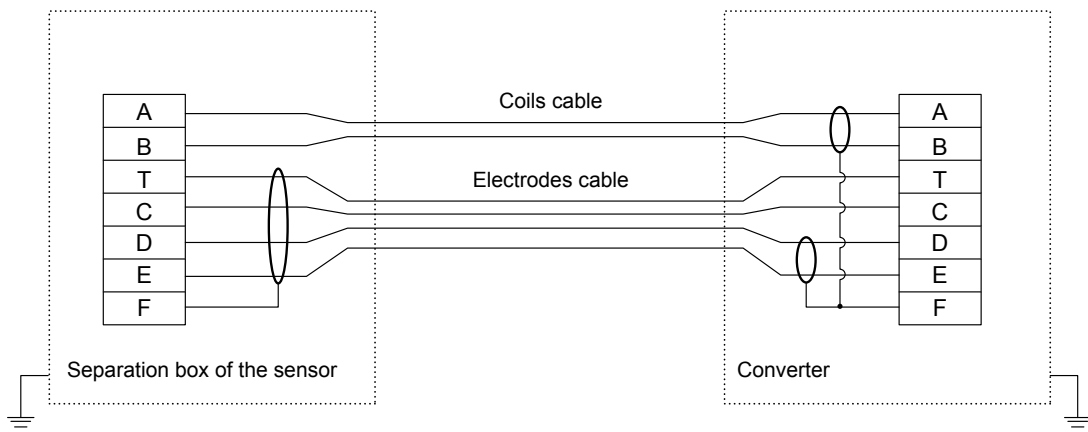

Fig. 53 Standard single-shielded cables - C028

5.3 SEPARATION CABLES

Optional single-shielded electrode cables - C022

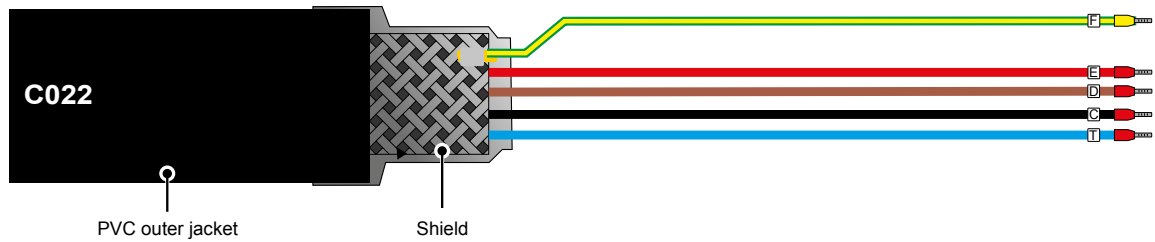

Fig. 54 Standard single-shielded electrode cables - C022

Optional double-shielded electrode cables - C028

C028 cables are provided with double shielding, one external, and one additional shielding of the single signal cables of the measuring electrodes only.

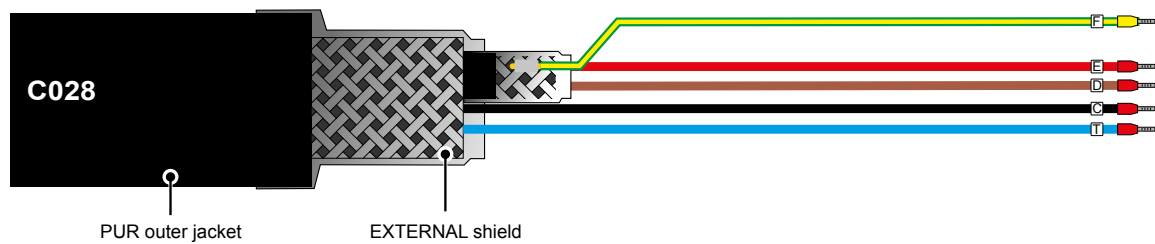

Fig. 55 Optional double-shielded electrode cables - C028

6 PRESSURE TAP

The MUT2200EL sensor can be optionally supplied with a 1/8" GAS pressure plug to which a pressure transducer can be connected.

The pressure transducer can be supplied by Euromag on request, and it will be integrated into the converter, or a third-party sensor can be used.

It is recommended to place a valve between the pressure tap and the transducer so that the transducer can be assembled and disassembled while keeping the pipeline under pressure.

Characteristics and dimensions of the pressure transducer supplied by Euromag may vary depending on the model of the connected converter.

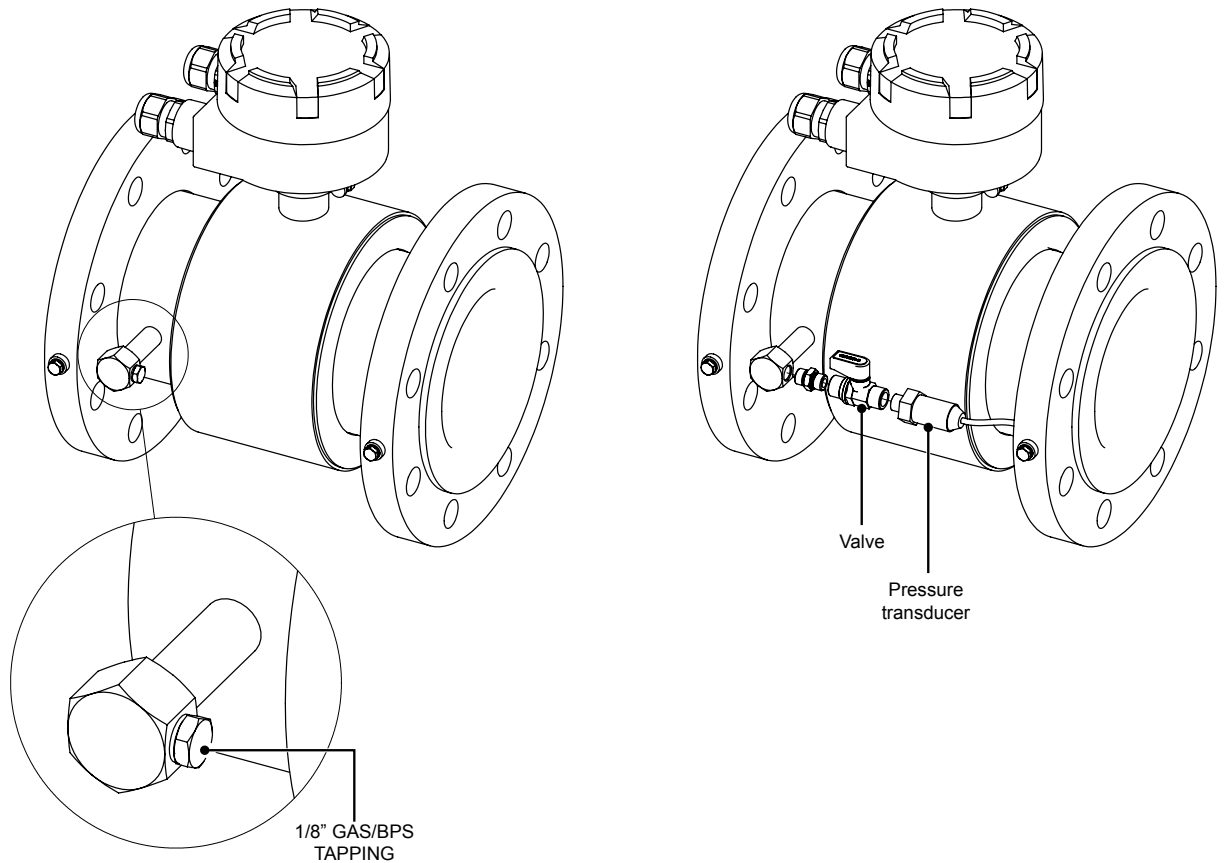

Fig. 56

7 INSERTION METERS

7.1 INTRODUCTION

The insertion flowmeters are intended to be inserted inside existing pipes, with minimal intervention on the existing system, through a threaded or flanged sleeve and possibly a valve.

The meter can be installed in any pipe of internal diameter between DN50 and DN2600.

This type of sensor is designed for use in survey applications, such as leakage monitoring and network analysis, and in permanent locations where cost or space limitations preclude the use of conventional flowmeters.

7.1.1 7.1.1 Operating principle

In accordance with the international standard ISO 7145 - *Determination of flow rate of fluids in closed conduits of circular cross-section - Method of velocity measurement at one point of the cross-section*, based on a large number of experimental results it was possible to establish that, in turbulent conditions and within certain application limits*, the position of the circle centered on the axis of the tube, in which the local speed is equal to the average axial speed, remains fixed when the flow rate varies and is the same for any tube:

$$y_1 = 0,242 * R \approx \frac{1}{8} D_i$$

Where R is the radius of the passage section and D_i the internal diameter of the same.

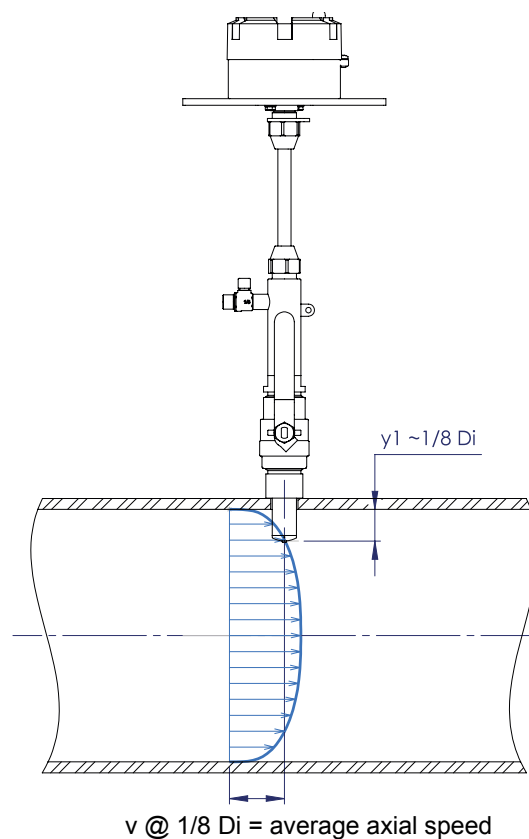
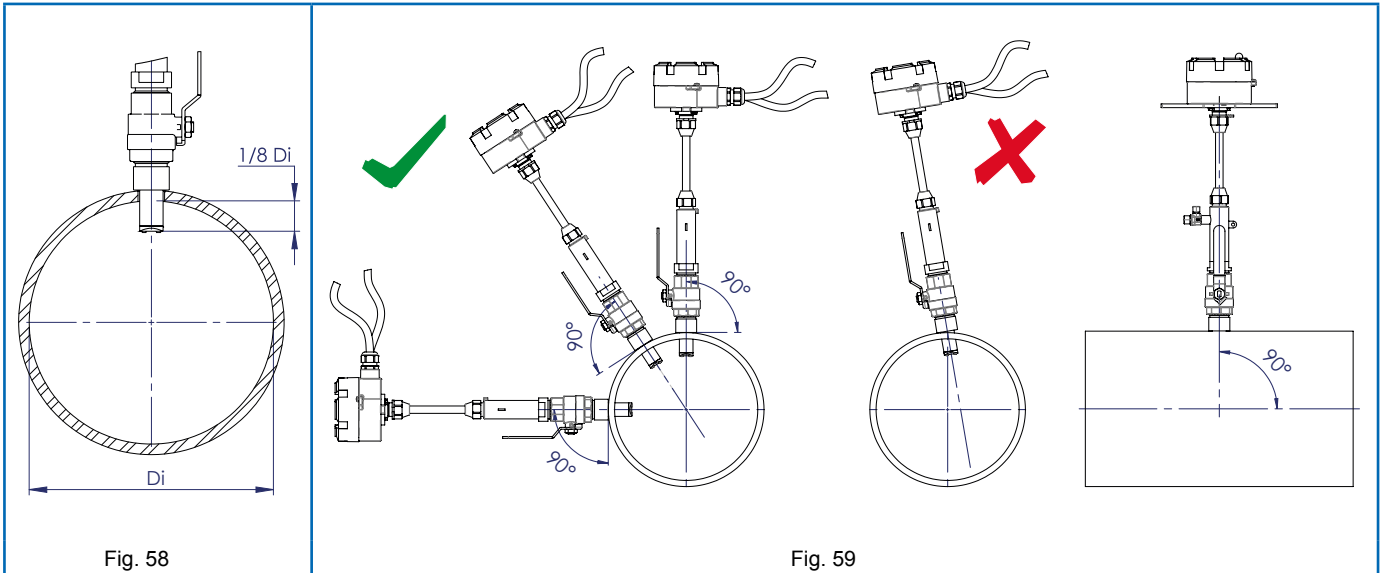

Fig. 57 Operating principle

7.2 GENERAL INSTALLATION REQUIREMENTS

The probe must be installed at the point of average axial speed, which is located at 1/8 of the internal diameter of the pipe (Fig. 58).

The meter axis must intercept the pipe axis (Fig. 59).



The pipe must always be full of liquid (see Fig. 60).

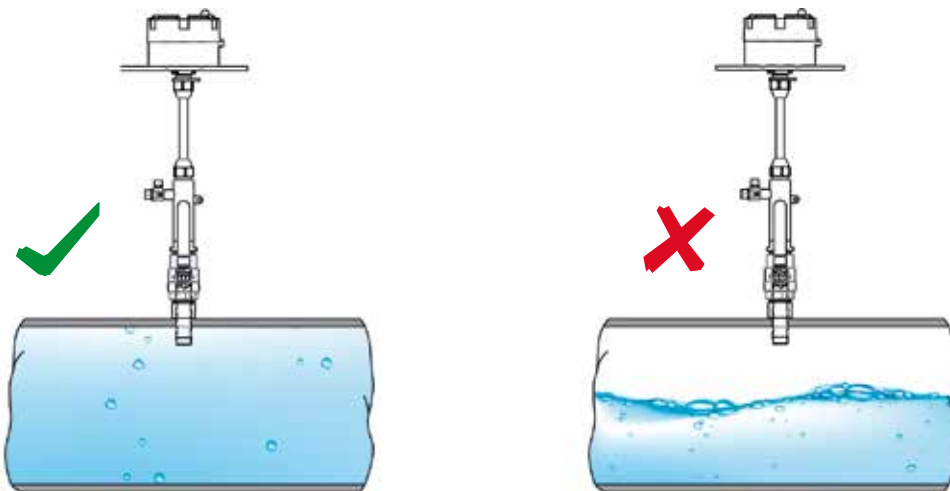

Fig. 60

7.2.1 Care of the device



- The measuring head of the insertion sensor is a delicate part of the measuring instrument and must be handled with care.
- **By removing or inserting the measuring head in the pipe, make sure that the valve is completely open to avoid damage to the sensor. If there is no valve, check that the insertion sleeve is not obstructed. Any damage to the measuring head could compromise the meter and its performance.**
- Any physical damage to the sensor probe will void the warranty.

7.2.2 Alignment of the electrodes in relation to the flow

The measurement of the flow is directly linked to the component of the distance between electrodes perpendicular to the flow axis, d' .

If the electrodes are positioned perpendicularly to the flow direction, $d=d'$, where d is the distance between the electrodes.

If the electrodes are rotated by an angle φ , $d' \neq d$ and an error in the measurement will, therefore, be introduced.

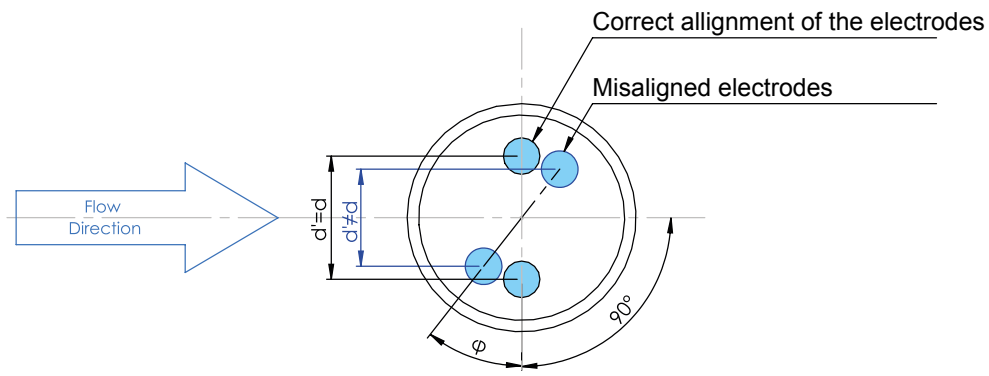

Fig. 61

It is essential to carefully position the electrodes in relation to the direction of the pipe.

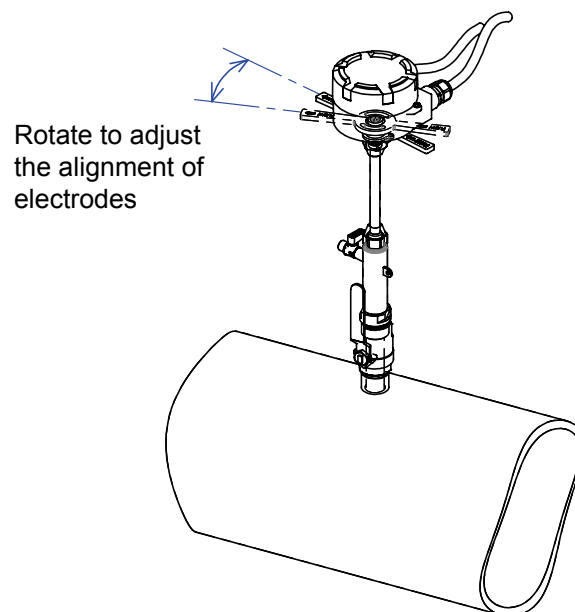

Fig. 62

7.3 MUT1222

7.3.1 Dimensions and main features

The MUT1222 flowmeter is available in three different sizes and can be installed in pipes from DN50 to DN2600 by using a 1" valve. The sensor is equipped with Hot-Tap functionality (i.e., it is possible to assemble and disassemble the flowmeter with the pipe under pressure and full of liquid). It also has a 1/8" pressure tap.

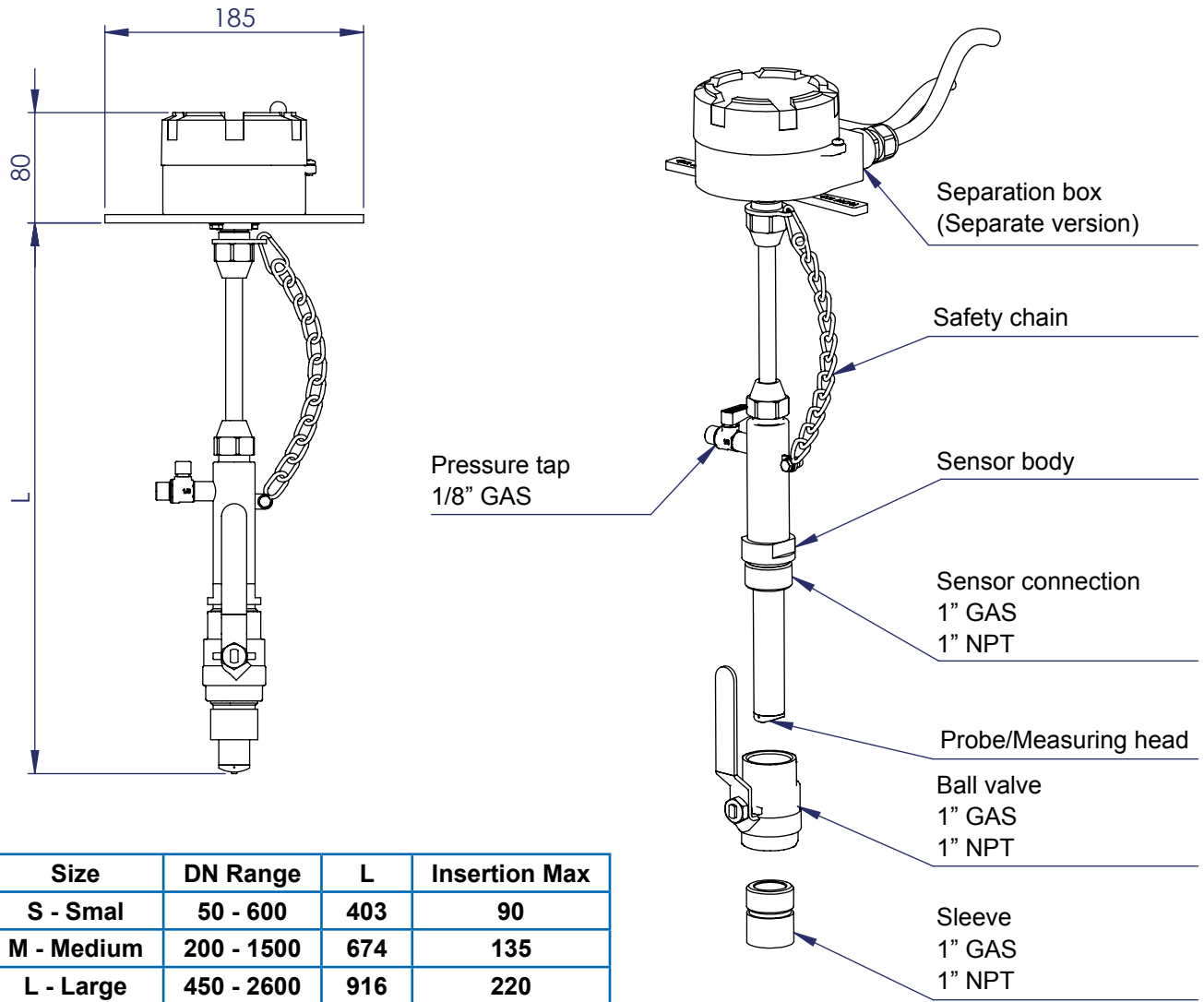

Fig. 63



ATTENTION: Inserting a device, flow sensor, etc., inside a pressurized pipe can be dangerous. If the pipe pressure is high (greater than 5 bar), the insertion or removal of the sensor must be carried out with particular attention. In cases of pressure higher than 10 bar, the assembly or disassembly of the meter under pressure is not recommended. Instead, we recommend reducing the line pressure for the short period of time necessary to perform the assembly or disassembly operation. Keep in mind that, in general, the removal of the sensor can be more dangerous than the insertion of the same.

The MUT1222 sensor is equipped with a safety chain to prevent the rapid exit of the sensor rod, which could be dangerous for the operator.

In any case, the installation, assembly, and disassembly of the sensor must be carried out exclusively by expert and trained personnel.

7.3.2 Calculation of the insertion depth

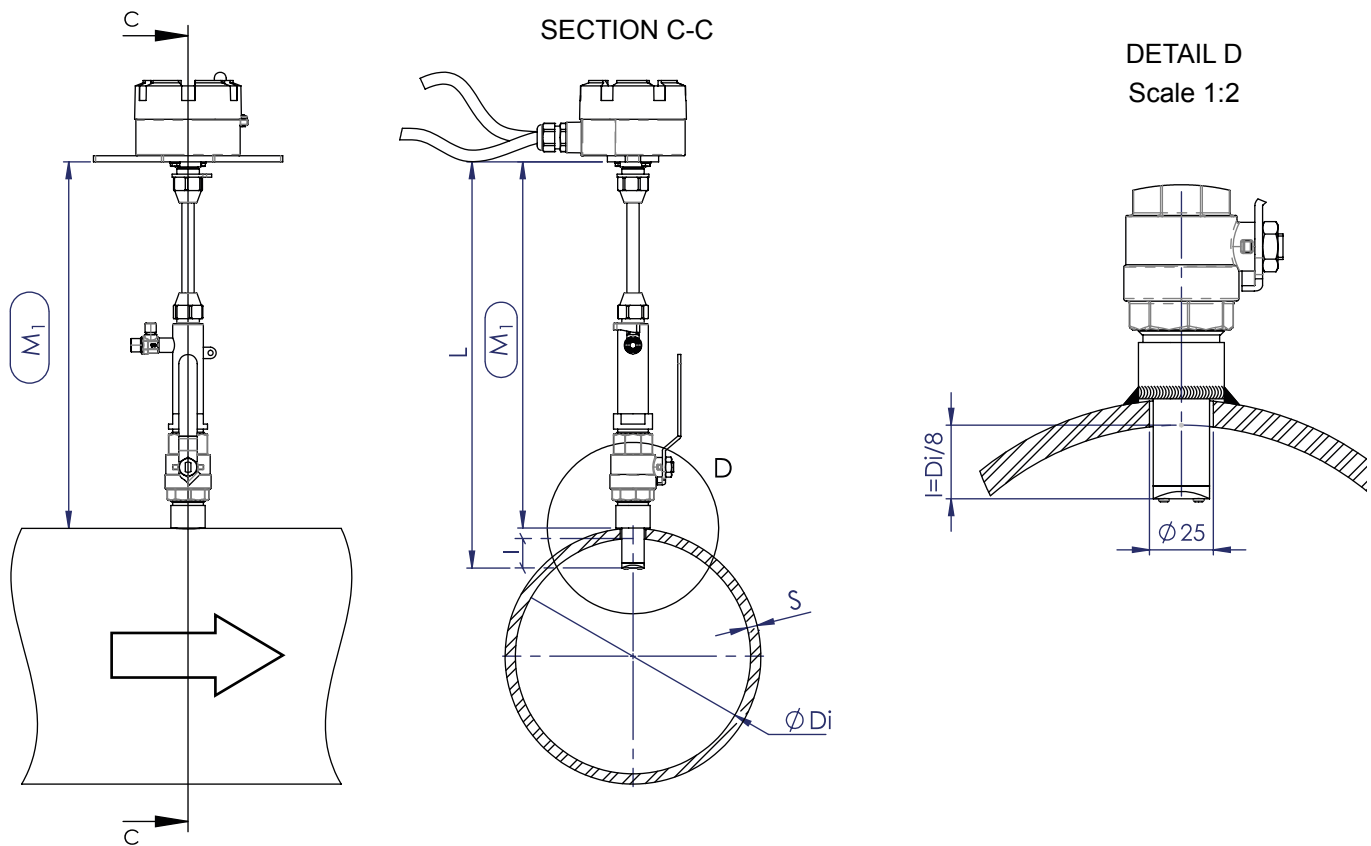

Fig. 64

The insertion depth I can be determined using the following formula:

$$I = \frac{D_i}{8}$$

In order to precisely set the insertion depth, it is possible to use the control value M_1 :

$$M_1 = L - S - \frac{D_i}{8}$$

Where:

- » L = Flowmeter length according to the table of Fig. 63
- » D_i = Internal pipe diameter
- » S = Thickness of the pipe, including possible coating

7.3.3 Installation of the sensor

7.3.3.1 Preparation of the pipe

⚠ ATTENTION: The preparation of the pipe can be carried out even on pressurized lines by using special machinery. Aside from the fact that this operation requires the use of special equipment, it is also intrinsically dangerous. Thus, it is recommended to rely exclusively on highly specialized personnel.

⚠ ATTENTION: Before inserting the sensor, check that the insertion hole is free from obstruction and/or burrs caused by preparation work because it could damage the device.

Drill the pipe at the installation point. The diameter of the hole must be $\varnothing 25 \pm 1\text{mm}$.

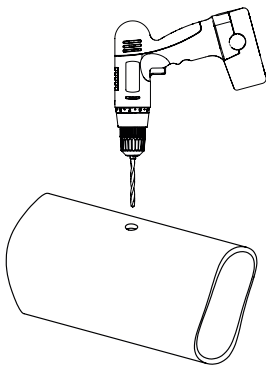

Fig. 65

Weld the threaded sleeve, paying the utmost attention to its correct orientation.

The axis of the sleeve must intersect the axis of the pipe and be perpendicular to it.

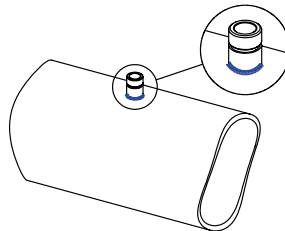

Fig. 66

Install the valve, use PTFE tape to ensure the tightness of the thread. Close the valve and pressurize the pipe if necessary.

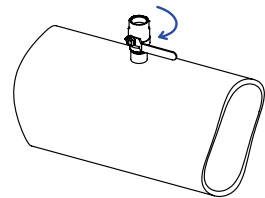

Fig. 67

7.3.3.2 Assembly of the flowmeter

Install the insertion meter, making sure that the stem is completely retracted to prevent the head with the electrodes from hitting the valve.

Use PTFE tape to ensure the tightness of the thread.

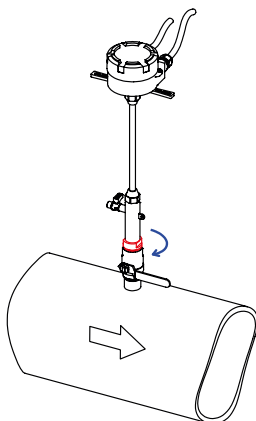

Fig. 68

1. Open the valve completely
2. Adjust the insertion depth
3. Adjust the alignment in relation to the pipe axis. The alignment precision must be within $\pm 2^\circ$.

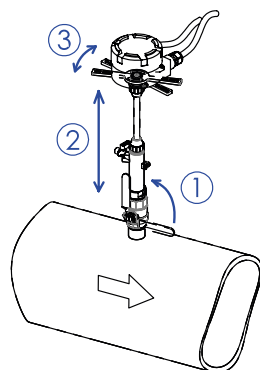

Fig. 69

Tighten the lock nut by applying a tightening torque of 40Nm (30 ft-lb).

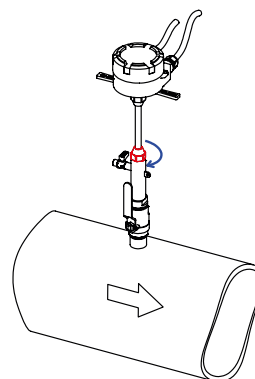

Fig. 70

Connect the safety chain by adjusting its length.

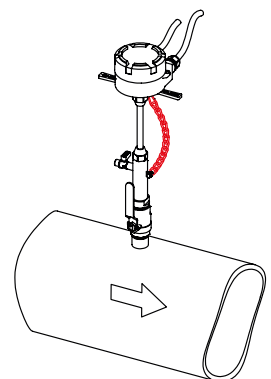

Fig. 71

7.3.4 Installation on non-metallic pipes using a saddle bracket

There are different types of saddle brackets available on the market that can be applied in pipes of different diameters. If an installation of this type is required, follow the instructions below.

NOTE: The maximum application diameter for each sensor size could be reduced due to the different height between the pipe and the valve.

Assemble the saddle bracket at the point of installation.
Drill the pipe using the sleeve as a centering jig.
The diameter of the hole must be $\varnothing 25\pm 1\text{mm}$.

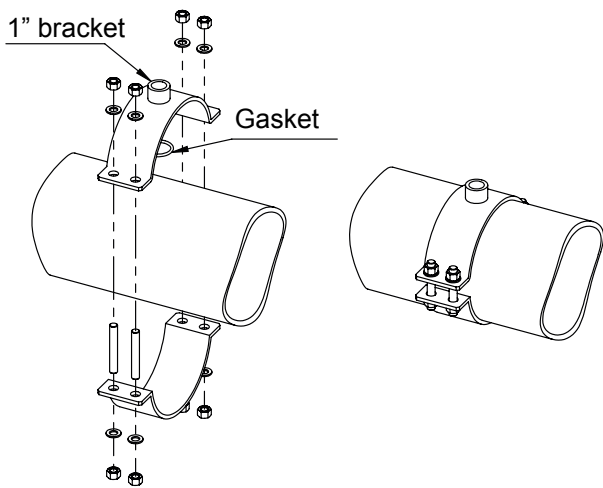

Fig. 72

If the saddle is equipped with a female thread, fit the valve using a 1" male X male nipple, otherwise set the valve directly on the saddle bracket.
Use PTFE tape to ensure the tightness of the thread.

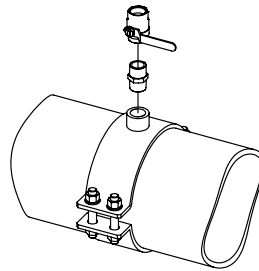

Fig. 73

Install the meter following the normal assembly instructions.

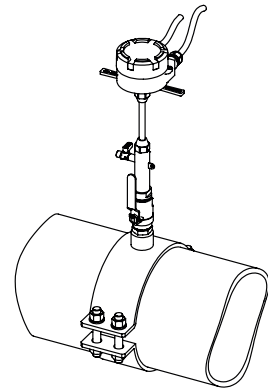

Fig. 74

7.3.5 Flowmeter grounding

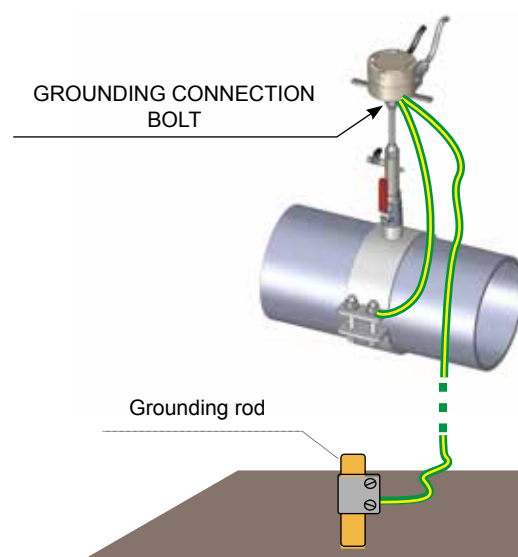
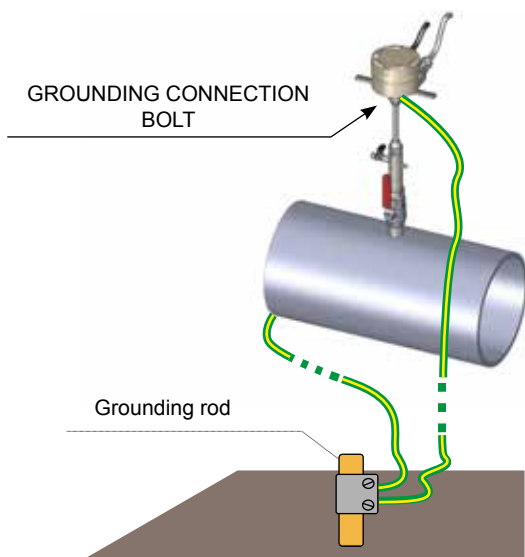

Fig. 75 Grounding

7.4 MUT2660

7.4.1 Dimensions and main features

The MUT2660 sensor is suitable for fixed installation in pipes from DN80 up to DN500.

The installation and assembly/disassembly of the flowmeter requires a 40mm hole drilling on the pipe and a threaded sleeve welding.



ATTENTION: For installation, assembly, and disassembly of the meter, the pipe must be empty—the sensor does not have Hot-Tap functionality. The maximum pressure at which the meter can operate is 10bar.

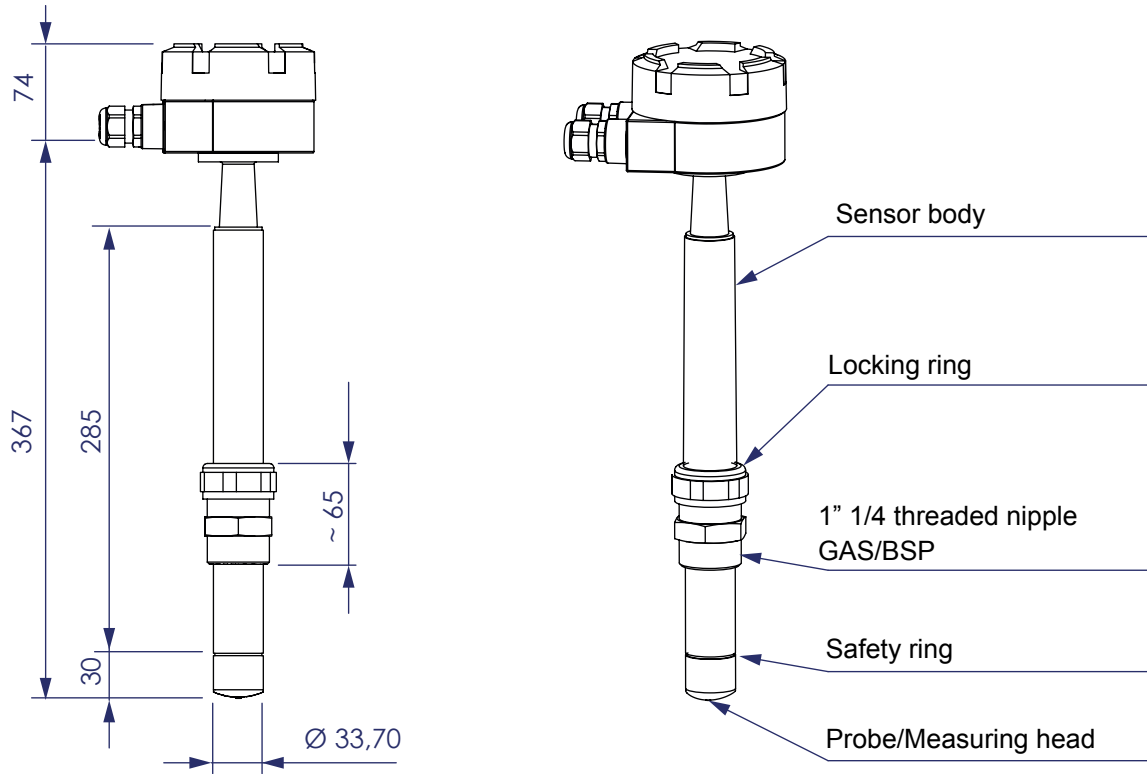

Fig. 76

Main features	
DN Range	DN 80 - DN 500 3" - 20"
Maximum pressure	10 bar
Temperature limits (process)	-20°C ÷ +80°C -4°F ÷ +176°F
Protection class - Separate	IP68
ATEX/IECEX (only Separate)	Ex mb IIC T6...T4 Gb Ex mb IIIC T85°C...T135°C Db -20°C ≤ Ta ≤ +60°C

Materials in contact with the liquid	
Sensor body	AISI316
Measuring head	POM
Electrodes	AISI316L
Safety ring	AISI304
Sensor body	Brass
O-Ring	NBR

7.4.2 Calculation of the insertion depth

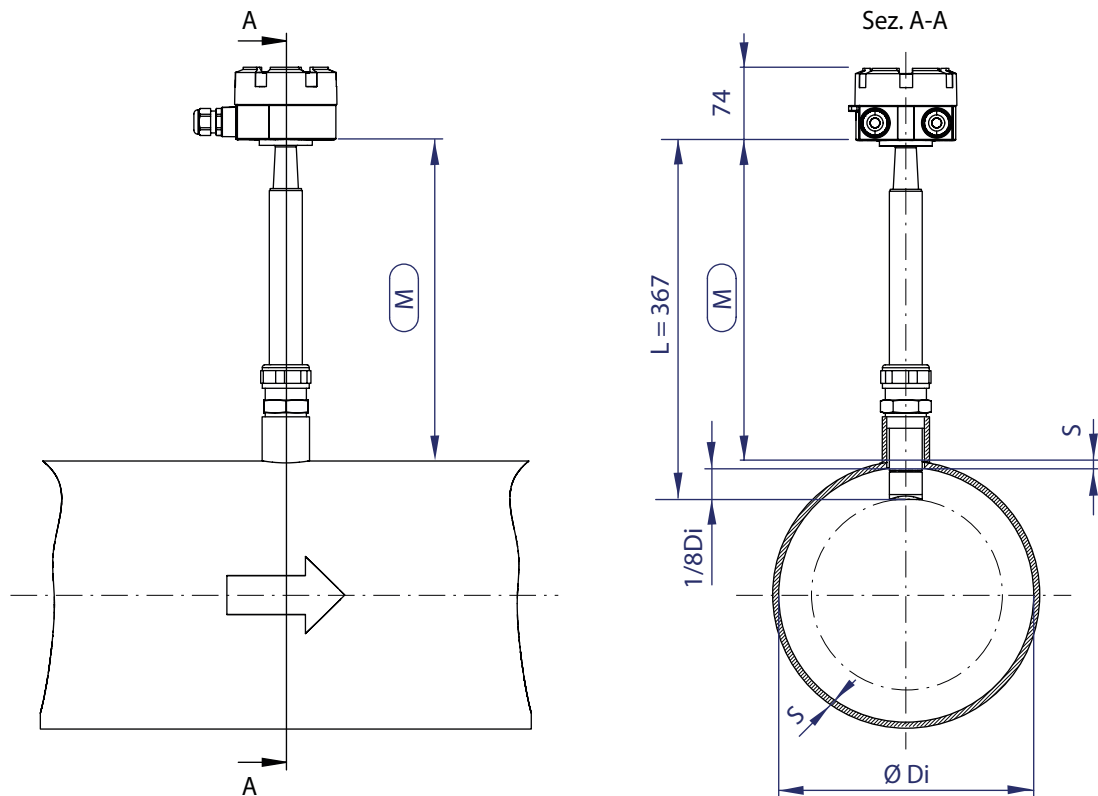

Fig. 77

The insertion depth I can be determined using the following formula:

$$I = \frac{D_i}{8}$$

In order to precisely set the insertion depth, it is possible to use the control value M :

$$M = L - S - \frac{D_i}{8}$$

Where:

- » L = Flowmeter length = 367mm
- » D_i = Internal pipe diameter
- » S = Thickness of the pipe, including possible coating

7.4.3 Installation of the sensor

! ATTENTION: The sensor is equipped with a safety device (consisting of a stop ring) designed to prevent the pressure from leaking out of the sensor in case the locking ring accidentally unscrews. Do not, under any circumstances, remove this safety device. The safety device prevents the sensor from coming out of its seat, but not from its moving, which can be sudden and potentially dangerous in the case of high line pressure.

! ATTENTION: The installation, assembly, and disassembly must be done when the pipe is empty.

7.4.3.1 Preparation of the pipe

Drill in the installation position.
The hole must have a minimum diameter of $\varnothing 40\text{mm}$ in order not to interfere with the sensor head.

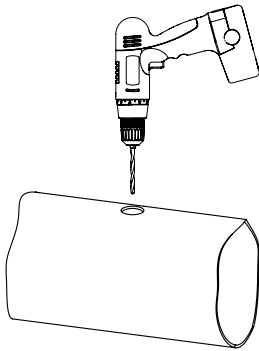

Fig. 78

Weld a 1"1/4 GAS threaded sleeve to the pipe, centering it correctly on the hole.

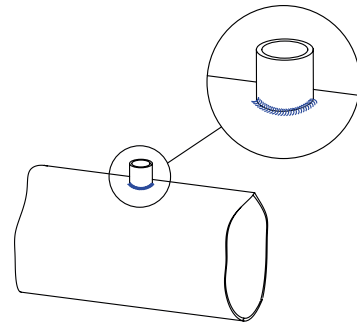

Fig. 79

7.4.3.2 Installation of the flowmeter

! ATTENTION: Before inserting the sensor, check that the insertion hole is free from obstruction and/or burrs caused by preparation work because it could damage the device.

Insert the sensor into the threaded sleeve, taking care not to damage the measuring head.

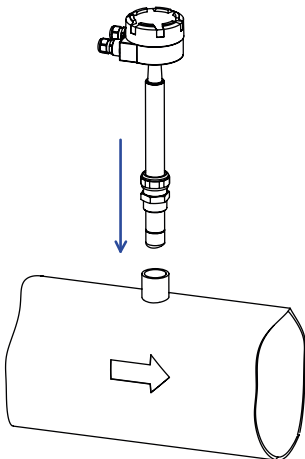

Fig. 80

Tighten the nipple on the sleeve. Use the PTFE tape to ensure water tightness.

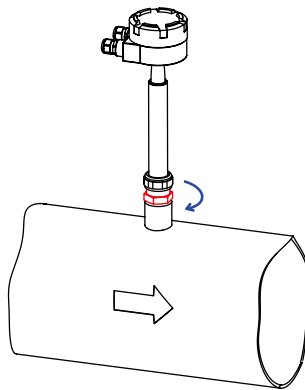

Fig. 81

Adjust the alignment of the sensor in relation to the pipe (with an accuracy of $\pm 2^\circ$) and the insertion depth.

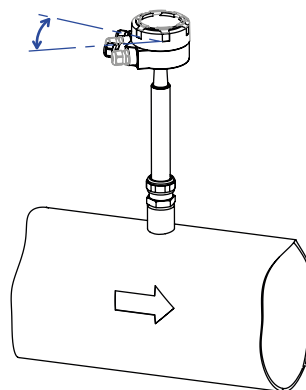

Fig. 82

Tighten the upper ring nut of the nipple to lock the sensor in place.

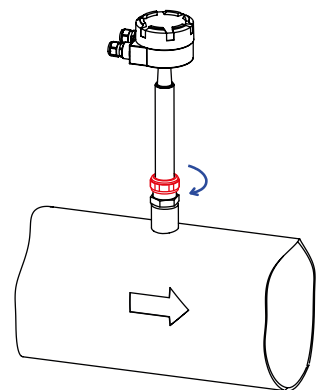

Fig. 83

7.4.4 Flowmeter grounding

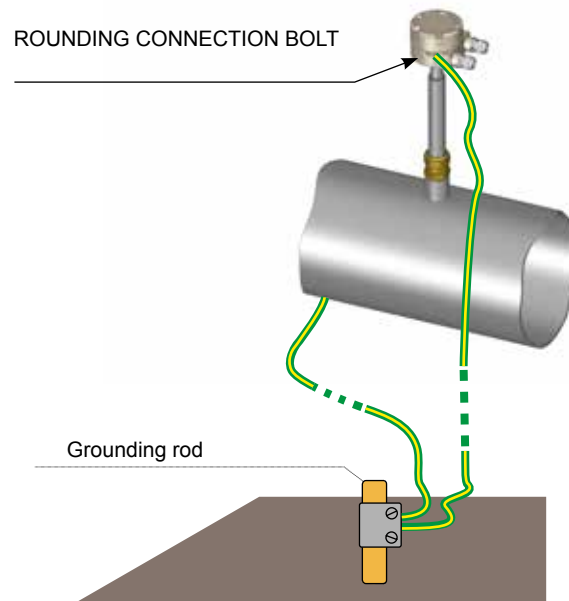

Fig. 84 Grounding

7.5 MUT2770

7.5.1 Dimensions and main features

The MUT2770 sensor is suitable for fixed installation in medium-large diameter pipes. It can be supplied in different sizes depending on the size of the pipe in which it will be installed, starting from a minimum of DN100 up to DN2500.

The installation and assembly/disassembly of this meter requires a 50mm hole drilling on the pipe and a flanged sleeve welding.



ATTENTION: For installation, assembly, and disassembly of the meter, the pipe must be empty—the sensor does not have Hot-Tap functionality. The maximum pressure at which the meter can operate is 25bar.

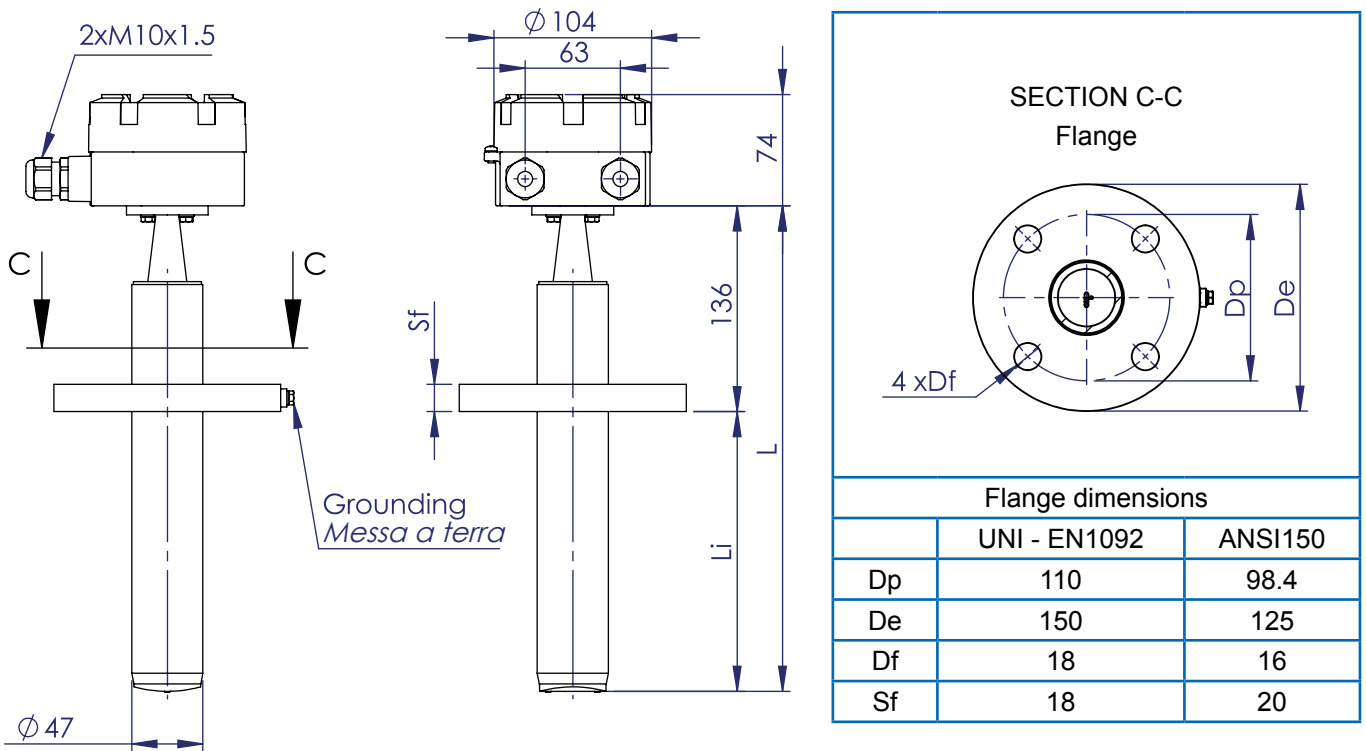
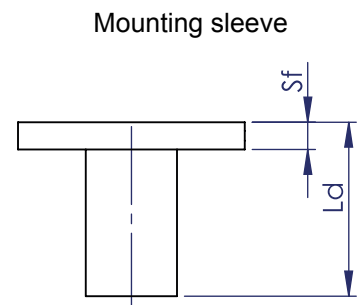

Fig. 85



NOTE: The supply of the flowmeter includes a flanged sleeve that has to be installed on the pipe after cutting it to the right size.

Size	DN Range	L	Li	Ld
A	100...500	251	115	115
B	600...1100	321	185	115
C	1200...1600	400	264	115
D	1700...2100	466	330	115
E	2200...2500	555	419	141



7.5.2 Calculation of the insertion depth

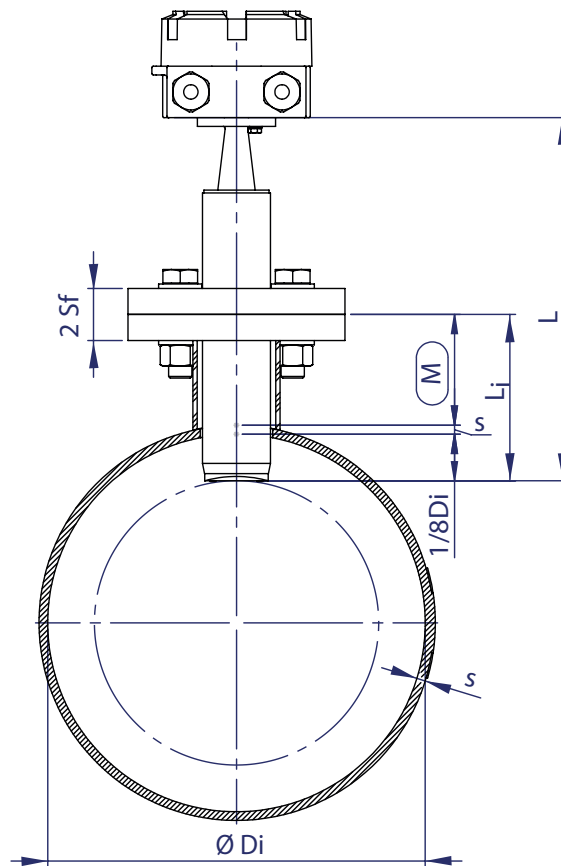

Fig. 86

The insertion depth I can be determined using the following formula:

$$I = \frac{D_i}{8}$$

In order to precisely set the insertion depth, it is possible to use the control value M :

$$M = L_i - S - \frac{D_i}{8}$$

Where:

- » L_i = Sub-flange length of the flowmeter
- » D_i = Internal pipe diameter
- » S = Thickness of the pipe, including possible coating

7.5.3 Installation of the sensor



ATTENTION: For installation, assembly, and disassembly of the meter, the pipe must be empty.

7.5.3.1 Preparation of the pipe

Drill in the installation position.
The diameter of the pipe must be $\varnothing 50$ mm.

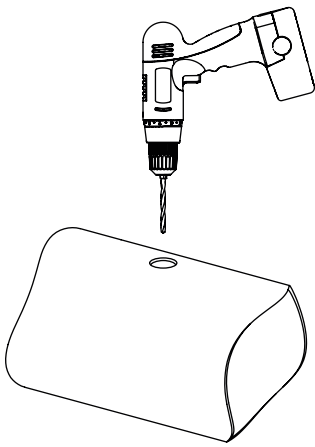

Fig. 87

Prepare the flanged sleeve for assembly by cutting it to length M and weld it to the pipe, taking into consideration the following:

- » The perpendicularity of the sleeve axis in relation to the pipe axis
- » The rotation of the sleeve flange in relation to the pipe axis
- » Respect the fluid direction indicated by the arrow to get a correct reading

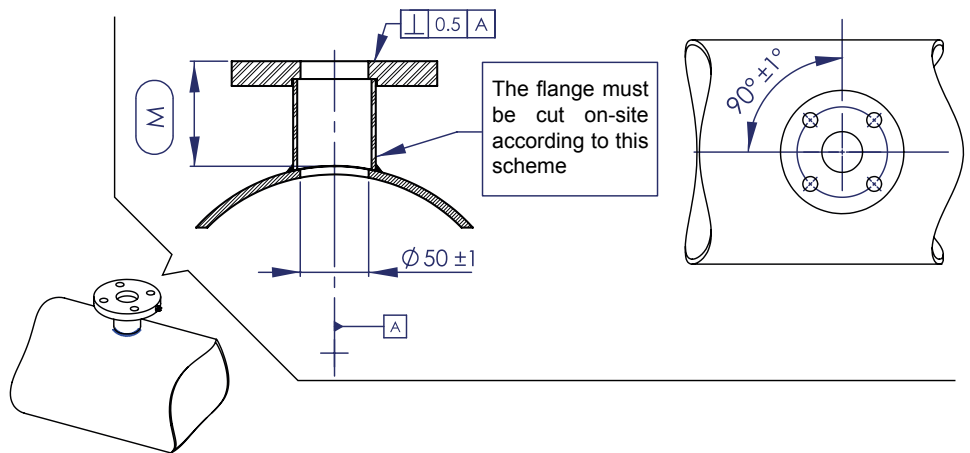

Fig. 88

7.5.3.2 Installation of the flowmeter



ATTENTION: Before inserting the sensor, check that the insertion hole is free from obstruction and/or burrs caused by preparation work because it could damage the device.

Insert the O-Ring gasket in the sensor stem.
Insert the sensor in the flanged sleeve, aligning the holes.

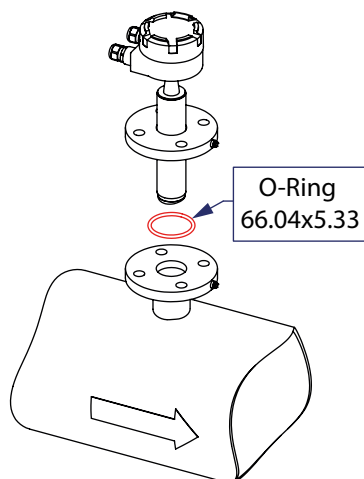

Fig. 89

Insert the fixing bolts to secure the sensor flange to the flanged sleeve attached to the pipe.

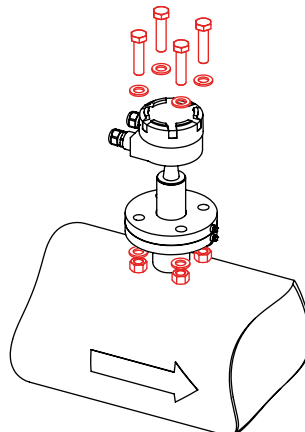

Fig. 90

Tighten the bolts to block the position of the sensor.

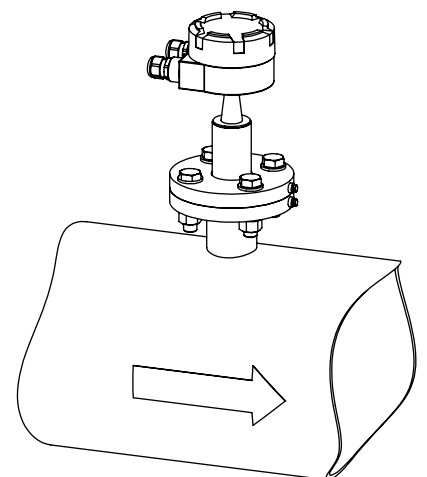

Fig. 91

7.5.4 Flowmeter grounding

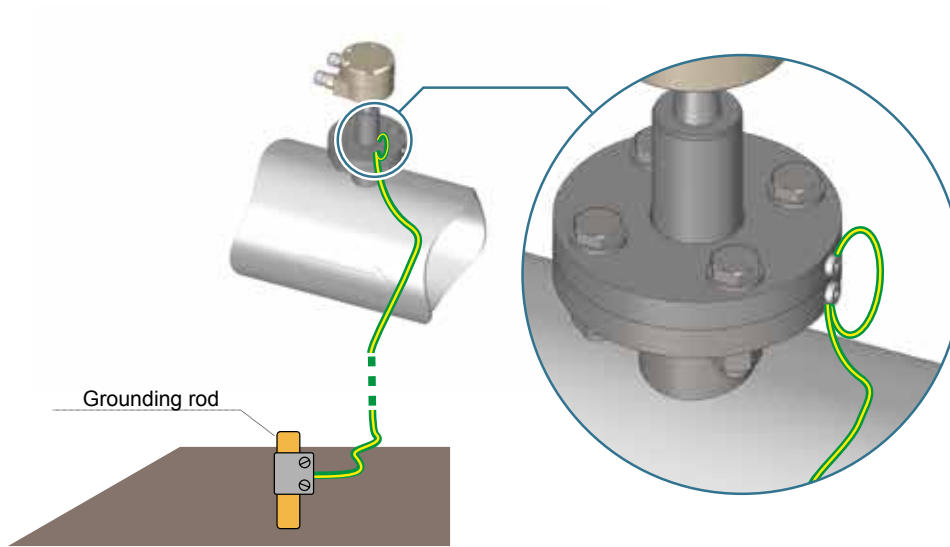

Fig. 92 Grounding

8 MAINTENANCE

8.1 BOLTS TIGHTENING

Periodically check the tightness of all the fixing nuts. If necessary, ensure correct tightening by applying the tightening torques shown in the table in paragraph 3.4.3.

8.2 GROUNDING CHECK

Periodically check the earth connections, especially the integrity of the cables and terminals and remove any oxidation from the contacts.

8.3 CLEANING OF EBONITE COATINGS:

Cleaning and degreasing organic coatings is a delicate matter.

In the case of ebonite-coated **Euromag** flowmeters, please avoid any acid solution containing HF (hydrofluoric acid) in any concentration.

The basic solution, such as NaOH, can be used, but only at room temperature. Normal soap is recommended for removing grease and oil.

If cleaning with soap is not sufficient, washing with a solvent can also be carried out, using products which evaporate rapidly; for example, acetone. In this case, the dirt must be removed with a cloth moistened with acetone, an operation that must be done quickly to avoid aggression on the Ebonite, and immediately afterward, the surface must be dried with a blow of air to allow the solvent evaporation.

9 TROUBLESHOOTING

For the TROUBLESHOOTING section (Problems / Causes / Solutions), please refer to the instruction manual of the converter associated with the specific sensor.

10 CERTIFICATIONS AND TECHNICAL FEATURES

Please refer to the sensor and converter catalogs to see the list of the certifications and all the technical features related to your product.

11 SENDING THE FLOWMETER TO THE MANUFACTURER

The device was manufactured with extreme care and passed rigorous tests before shipment from the factory. If the installation and maintenance are carried out correctly, it is very unlikely that malfunction will occur.

However, if it should be necessary to send the device to our customer service for any checks or repairs, please pay attention to the following points:

- According to the legal provisions on environmental protection and securing the health and safety of our personnel, the manufacturer can only test and repair those devices returned to us that have been in contact with products that are risk-free for personnel and environment.
- This means that the manufacturer can perform the service on the device only if this is accompanied by the “repair request form,” stating that the device itself can be safely handled.

11.1 REPAIR REQUEST FORM



The “repair request” form shown below on page 52 must be photocopied, filled in, and attached to the device that needs to be checked/repared by our customer service.

 EUROMAG INTERNATIONAL	Modulo richiesta riparazione/ Return Merchandise Authorisation (RMA)	 QUALITY SYSTEM CERTIFICATE DNV-GL ISO 9001 COMPANY WITH QUALITY SYSTEM CERTIFIED BY DNV-GL = ISO 9001 =
---	---	---

Nome Azienda/ <i>Company Name</i>	
---	--

Indirizzo Azienda/ <i>Company Address</i>	
---	--

Tel.		Fax	
-------------	--	------------	--

Tipo di sensore/ <i>Sensor type</i>		N. di serie/ <i>Serial n.</i>	
---	--	---	--

Tipo di convertitore/ <i>Converter type</i>		N. di serie/ <i>Serial n.</i>	
---	--	---	--

Liquido trattato/ <i>Treated liquid</i>		Pulizia interna sensore/ <i>Sensor internal cleaning</i>	YES <input type="checkbox"/>
---	--	--	-------------------------------------

Reclamo/ <i>Claim</i>	

Data restit. richiesta/ <i>Required return date</i>		Data restit. confermata/ <i>Confirmed return date</i>	
---	--	---	--

<p>Con la presente si conferma che non vi è alcun rischio per le persone o per l'ambiente in conseguenza di sostanze residue contenute nel dispositivo che viene restituito. <i>We hereby confirm that there is no risk to persons or the environment due to any residual substances contained in the device that is returned.</i></p>

Data/ <i>date</i>	
-----------------------------	--

Timbro azienda/ <i>Company stamp</i>		Firma/ <i>Signature</i>	
--	--	-----------------------------------	--

12 PRODUCT DISPOSAL

Disposal of the device no longer in use is the responsibility of the user, who must comply with the specific laws enforced in the country of installation regarding environmental protection.

MANUFACTURER'S STATEMENT

The manufacturer declares that the design, development, and construction of the CONVERTER have been carried out in compliance with the directive on the reduction of the use of dangerous substances with particular attention to waste electrical and electronic equipment (WEEE) supporting, from an environmental point of view and the protection of the health of the worker, the intervention of the subjects who participate in the installation, use, and disposal of their products (manufacturer, distributors, consumers, operators involved in WEEE treatment).

The crossed-out wheellie bin symbol (Fig. 92) contained on the equipment indicates that the product must be collected separately from other waste at the end of its useful life.

Therefore, the user must give the equipment at the end of its life to the appropriate waste collection centers for waste electrical and electronic equipment, or return it to the retailer when purchasing a new equivalent type of equipment on a one-for-one basis.

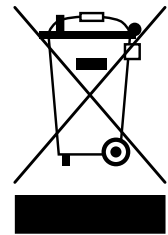

Fig. 93

Appropriate sorted waste collection for the next start-up of the disused equipment for recycling, treatment, and environmentally compatible disposal contributes to avoiding possible negative effects on the environment and favors the reuse and/or recycling of the materials of construction. Unauthorized disposal of the product by the user results in the application of the administrative sanctions provided for by applicable law.



EUROMAG
INTERNATIONAL

Measure > Sense > Innovate

EUROMAG INTERNATIONAL Srl

Via Della Tecnica, 20 - 35035 Mestrino (PD) - ITALY
Tel. +39/049 9005064 - Fax. +39/049 9007764

euromag@euromag.com - www.euromag.com

ENGLISH
TD 217-1-ENG

