



EUROMAG
INTERNATIONAL

Measure > Sense > Innovate

SENSOR MUT1000EL

Electromagnetic flowmeter



The wafer electromagnetic flowmeter



DS120-5-ENG



Sensor MUT1000EL

MUT1000EL sensors represent the state of the art of Euromag International production for water cycle and process applications. The new structure for the generation of the magnetic field and the innovative route of the signal generated by the electrodes, provide a sensor with an extremely wide measurement range:

EL= Extended Linearity

This new sensors series follows the successful tradition of the MUT1000EL, introducing a measurement range of more than 1:1000 without linearization software. These kinds of performances allow very accurate measures on a wide flowrate range and to count lower flow rates that, before, would have been reset because of the effect of the converters cut off.

This flanged sensors series bases its operation on the Faraday Principle, by which a conductor crossing a magnetic field generates a potential perpendicularly orientated to the same field.

In this case the flow tube made in stainless steel AISI 304 is equipped with carbon steel or stainless steel flanges, two coils are installed on the top and inferior part; the magnetic field, generated by the electric current crossing the coil, induces in the electrodes a difference in the potential proportional to the flow rate.

With the aim of measuring such potential of very low values, the interior of the flow tube is electrically insulated, thus the process liquid is no longer in contact neither with the material of the flow tube nor with that of the flange.

The converter used generates the current supplying the coil, acquires the electrodes difference of potential, process the signal to calculate the flowrate and administers the communication with the exterior.

The entire sensor, when installed in the separate version, has a degree of protection IP68 suitable for a permanent immersion in water up to a depth of 1.5m thanks to a welded plate structure containing the coil and the electrodes.

Body and connection

MUT1000EL SENSORS have the flow tube made in stainless steel AISI 304 and the structure is made in acrylic painted carbon steel. This treatment gives the sensor an excellent resistance to water, even in permanent immersion. It is equipped with a junction box to connect the cables to the converter. Its standard degree of protection is IP68, suitable for a permanent immersion in water at 1,5m. It is installed between flanges UNI 2223 from PN 16 to PN 40 or between flanges ANSI 150, 300.



Internal lining

The standard internal insulating lining is in PTFE for diameters from DN25 to DN100, in hard rubber for food stuff (ebonite for food) for diameters of more than DN100. On request the sensors may be supplied coated with PTFE for diameters of more than DN100. The temperature of the liquid to be measured is limited by the type of internal lining used.

Electrodes and grounding

The standard electrodes are in Hastelloy C and, therefore, guarantee a wide compatibility with the process liquids, if required they may be supplied in other materials. A grounding electrode and an empty pipe electrode are also provided to monitor conditions of partly filled pipe.

Coupling and sensor connection

MUT1000EL sensors may be coupled with any Euromag converters. In the separate version the sensor is connected to the converter by means of cables whose length depends on the liquid conductivity; the maximum length shall not exceed 100 metres (30 meters in combination with battery operated electronics).

Calibration and maximum error

Each sensor is calibrated on an hydraulic test rig equipped with a ISO17025 traceable weighing system. The accuracy is equal to $0,2\% \pm 2\text{mm/s}$ ($0,2\% \pm 1\text{mm/s}$ on request). The repeatability of the measure is about 0,1%. Bi-directional measure. On request the sensors can be supplied certified MID OIML R49 (if coupled to MC406M converters) for custody transfer.

Reference standards

The Euromag magnetic meters are marked CE and are manufactured according to the following standards:

- 2014/35/EU - EN 61010-1:2013 (LVD)
- 2014/30/EU - EN 61326-1:2013 (EMC)
- OIML R49-1:2013
- European directive 2014/32/EU (MID)
- 2014/34/UE - IEC 60079 - 0, IEC 60079 - 18 (ATEX - IECEx) Separate version
- EN ISO 15609-1 and EN ISO 15614-1
- UNI EN ISO 12944-2, painting for C4 class environments (on request)
- PTFE conform to the norms WRAS, FDA, DPR 777/82 e DM 21/09/773
- Ebonite conform to the norms WRAS, FDA e DM174



Available electrodes

* Hastelloy C (standard)	* Titanium
* Hastelloy B	* Tantalum
	* Platinum

General characteristics of MUT1000EL sensors

Available diameters[mm]	25 mm 1"	40 mm 1.1/2"	50 mm 2"	65 mm 2.1/2"	80 mm 3"	100 mm 4"	125 mm 5"	150 mm 6"	200 mm 8"	250 mm 10"	300 mm 12"
Joints: coupling flanges	EN1092-1, ANSI 150, ANSI 300, ANSI 600, ANSI 900, DIN 2501, BS 4504, AS 2129 (TABLE D - E - F), AS 4087, ISO 7005-1, KS 10K										
Maximum pressure	40 bar for diameters < DN150						16 bar for diameters > DN200				
Internal lining and liquid temperature [1]	Internal lining						Liquid temperature				
	PTFE						Standard -40 /+130°C (up to +180° on request)				
	Ebonite						-40°C / +80°C				
Degree of protection	IP68 continuous immersion at a 1,5 m (EN 60529)										
Compatible converters	MC608 A/B/R/P/I, MC406										
Electric connections	Cable glands M20 x 1.5 + terminal block + sealing resin										

[1] Compact version Tmax 80°C.

Weight of MUT1000EL sensors in the separate version without package

DN	[mm]	25	40	50	65	80	100	125	150	200	250	300
DN	["]	1"	1" 1/2	2"	2" 1/2	3"	4"	5"	6"	8"	10"	12"
WEIGHT	[kg]	2,1	2,5	3,0	4,5	6,5	7,5	9,5	11,5	17	21	26

MUT1000EL

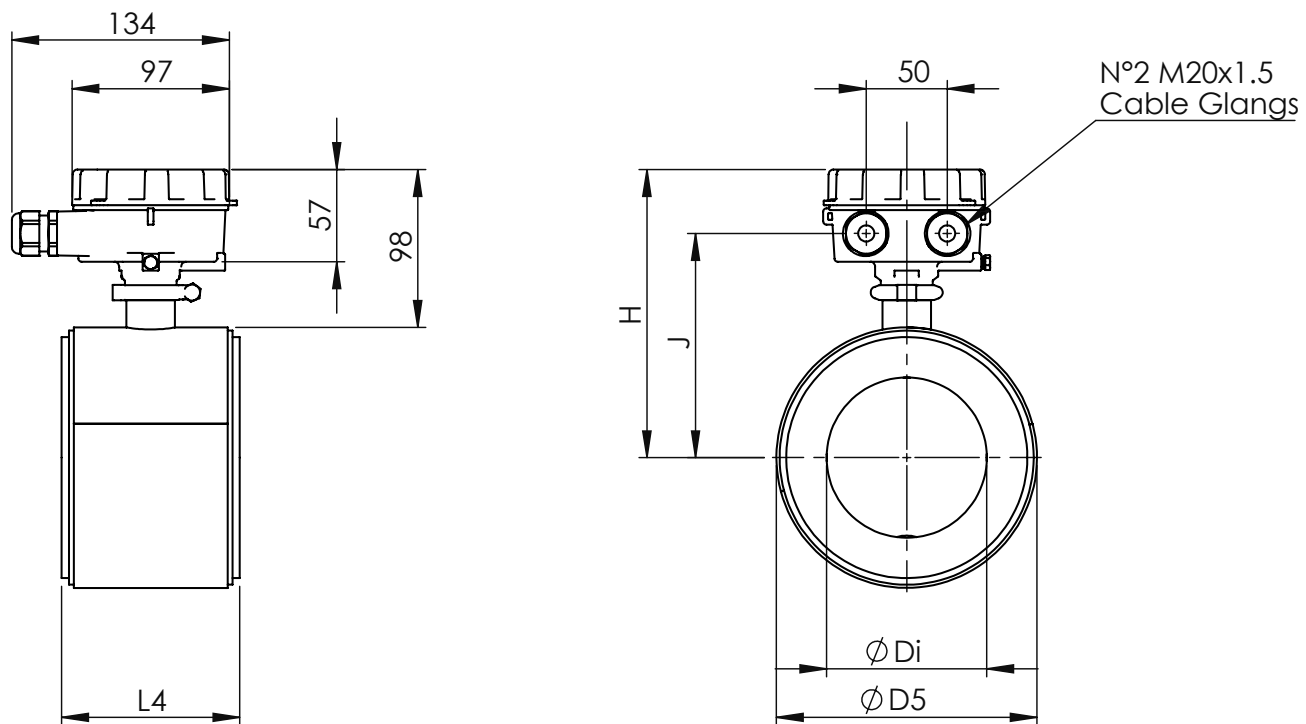

DN	L4	Di	D5	H	J
25	90	24	74	135	95
32	90	32	83	140	100
40	90	35	88	142	102
50	90	47	102	149	109
65	100	63	114	155	115
80	90	75	127	162	122
100	110	99	161	179	139
125	110	124	186	191	151
150	130	152	216	206	166
200	170	201	267	232	192
250	170	255	319	258	218
300	200	308	371	284	244

MUT1000EL - MC608A/B/R

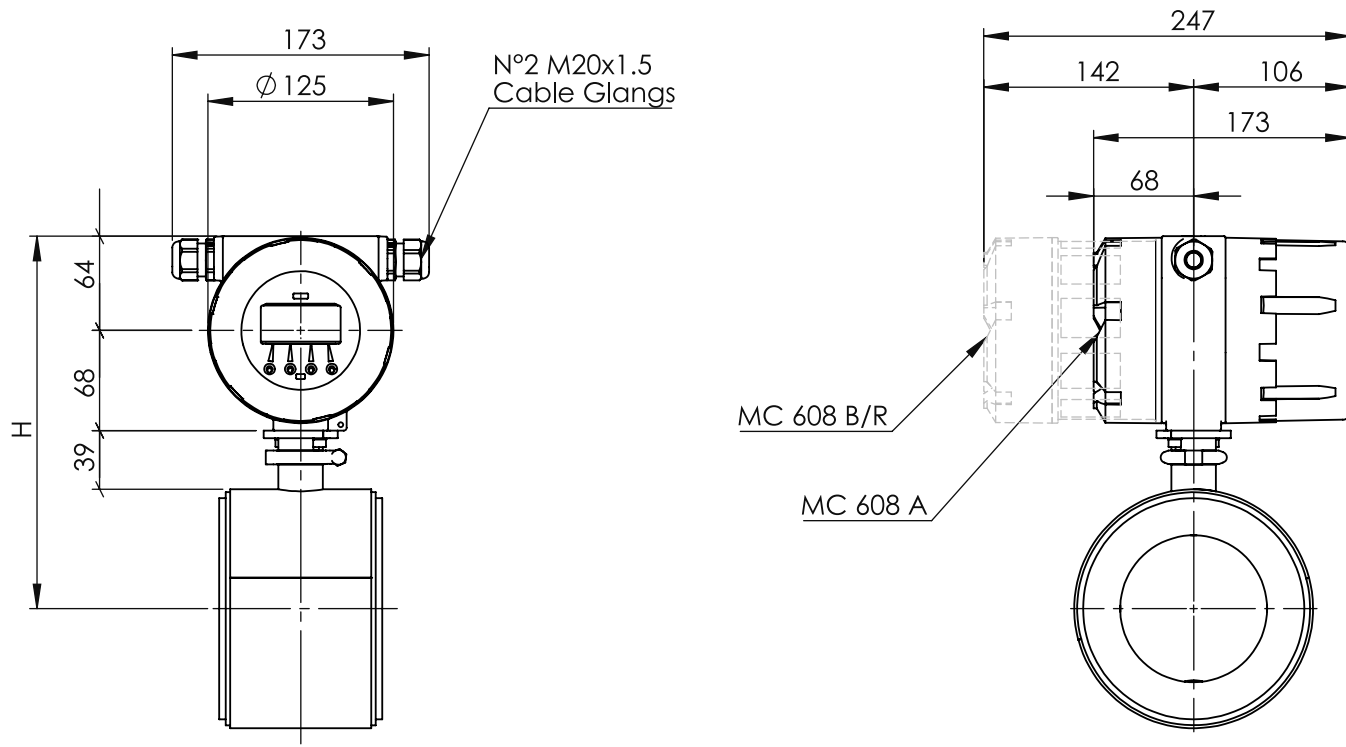

DN	H
25	208
32	213
40	215
50	222
65	228
80	235
100	252
125	264
150	279
200	305
250	331
300	357

MUT1000EL - MC406 VERTICAL

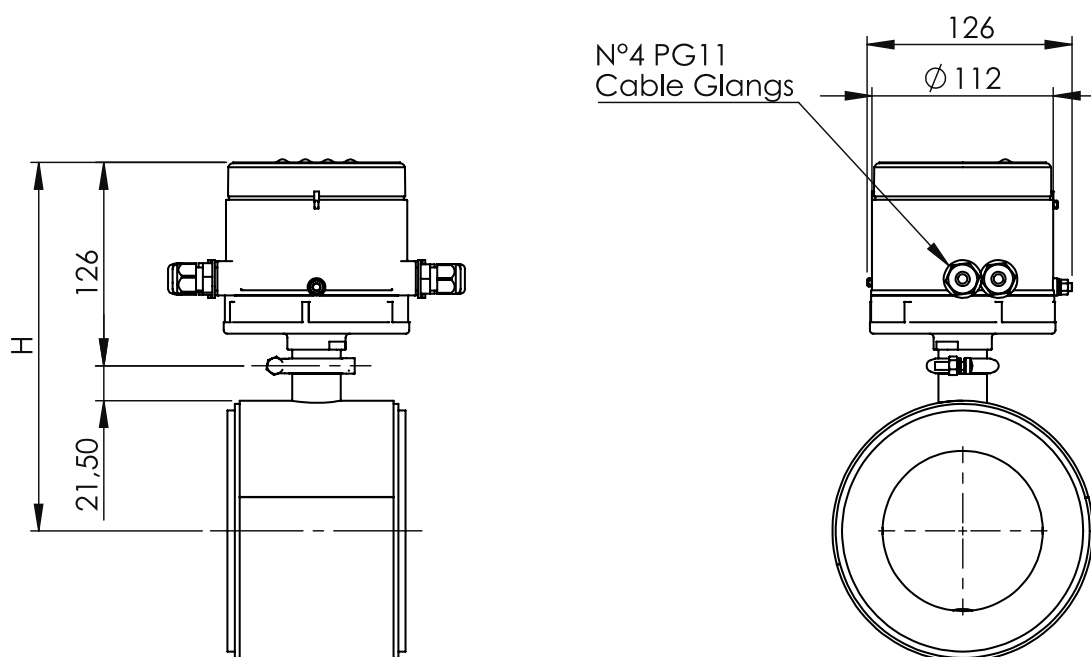

DN	H
25	184
32	189
40	191
50	198
65	204
80	211
100	228
125	240
150	255
200	281
250	307
300	333

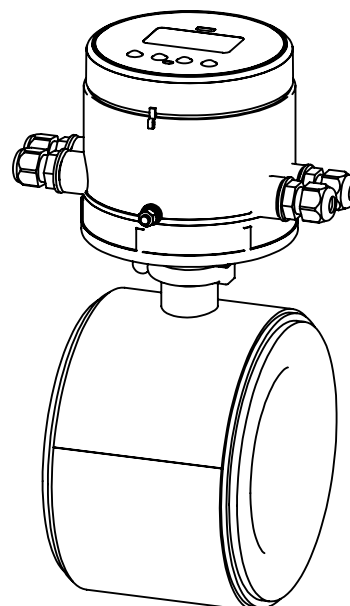
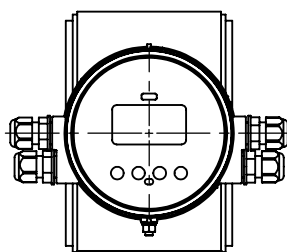



Measure > Sense > Innovate



EUROMAG
INTERNATIONAL

Measure > Sense > Innovate



EUROMAG INTERNATIONAL Srl

Via della Tecnica, 20 - 35035 Mestrino (Padova) Italia
Tel. +39 049.9005064 - Fax +39 049.9007764

www.euromag.com - www.euromagdata.com
euromag@euromag.com