



**EUROMAG**  
INTERNATIONAL

*Measure > Sense > Innovate*

# SENSOR MUT1222

Electromagnetic flowmeter



*The electromagnetic insertion flowmeter*



DS340-4-ENG



# SENSOR MUT1222

Electromagnetic  
flowmeter

## A COST EFFECTIVE ALTERNATIVE TO FULL-BORE METERS

EUROMAG INTERNATIONAL presents the new MUT1222 electromagnetic insertion flowmeter in three different sizes (small, medium and large) suitable to use in pipe size from DN 50 to 2600.

Delivering highly accurate bi-directional measurement for water distribution and raw water pipelines, it is robust and it has no moving parts, this allows to be reliable and suitable to measure a wide range of flows.

The MUT1222 can be used as a portable or a dedicated / permanent instrument; with its "hop tapping" application it is very easy and quick to install with no need to stop the flow under full working pressure conditions. It is an alternative solution to full bore metering and with its compact size allows installation on small pipes, providing water monitoring in applications considered impossible.

### Applications:

- Water network management
- Leakage control
- District metering
- Flow surveys
- Flow profiling
- Checking on-site flowmeters
- Data capture reporting and analysis

### Installation:

- Compact with converter MC608A/B/R
- Compact Vertical with MC406
- Separate (remote) with MC608A/B/R and MC406 with cables supply from factory (up to 30mt for battery powered, 100mt for mains powered version)

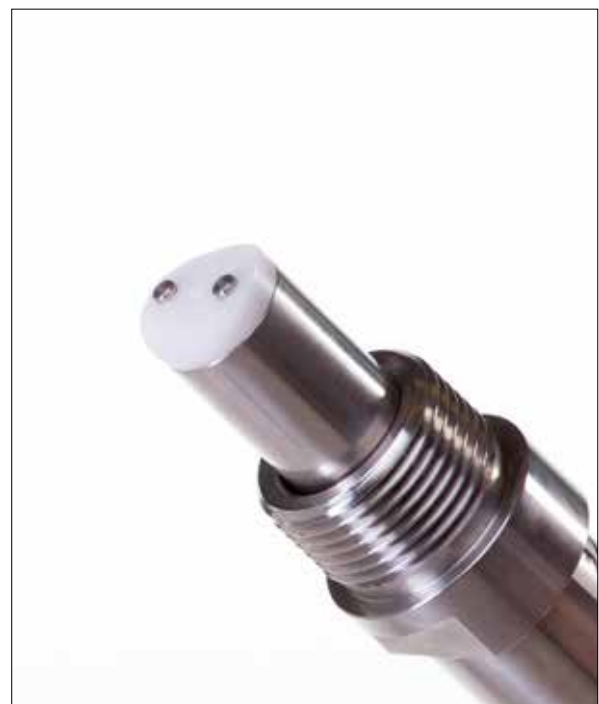

# SENSOR MUT1222

Electromagnetic  
flowmeter

## Equipment:

- 1" ball valve zinc plated brass
- "Hot tap" installation
- Head of the unit in POM 22mm
- Valve connection (female-female)
- Probe 12mm
- Pressure up to 20 bar
- Input connection for pressure gauge
- Handle grips with flow directions
- Body in AISI304
- 2 Electrodes in AISI316L
- ATEX on request (only separate version)

## Reference standards

The Euromag magnetic meters are marked CE and are manufactured according to the following standards:

- 2014/35/EU - EN 61010-1:2013 (LVD)
- 2014/30/EU - EN 61326-1:2013 (EMC)
- 2014/34/UE - IEC 60079 - 0, IEC 60079 - 18 (ATEX - IECEx) Separate version

## Temperature of liquid:

- 80° compact and separate version



## Technical features:

| Size range                   | Size Small (S)   | Size Medium (M) | Size Large (L) |
|------------------------------|--|-----------------|----------------|
|                              |  | 50...600        | 200...1500     |
| Available electrodes [*]     | AISI 316L  |                 |                |
| Body material                | AISI 304 Stainless Steel                               |                 |                |
| Head of sensor               | POM  |                 |                |
| Standard operating pressure  | 20 bar   |                 |                |
| Temperature of liquid        | -40 °C , +80 °C  |                 |                |
| Protection Degree            | IP68 for immersion at 1,5m (IEC 529)                   |                 |                |
| Converter compatibility      | MC608, MC406   |                 |                |
| Parts in contact with liquid | Head of sensor   | Electrodes      | Pipe end       |
|                              | POM  | AISI 316L       | AISI 304       |
| Electric connections         | Cable gland M20 x 1.5 + Terminal block + sealing resin |                 |                |

# SENSOR MUT1222

Electromagnetic  
flowmeter

## Advantages:

- No moving parts
- No pressure loss
- Long lasting stability and precision
- No filter needed, zero maintenance
- Extremely sturdy structure
- Internal parts protected by a bi-component resin in order to increase protection from external agents
- Bi-directional measure



Optional transport case



## Calibration and maximum error

Each sensor is calibrated on an hydraulic test rig equipped with a ISO17025 traceable weighing system. The accuracy is equal to 2% +/- 2 mm/s. Bi-directional measure.

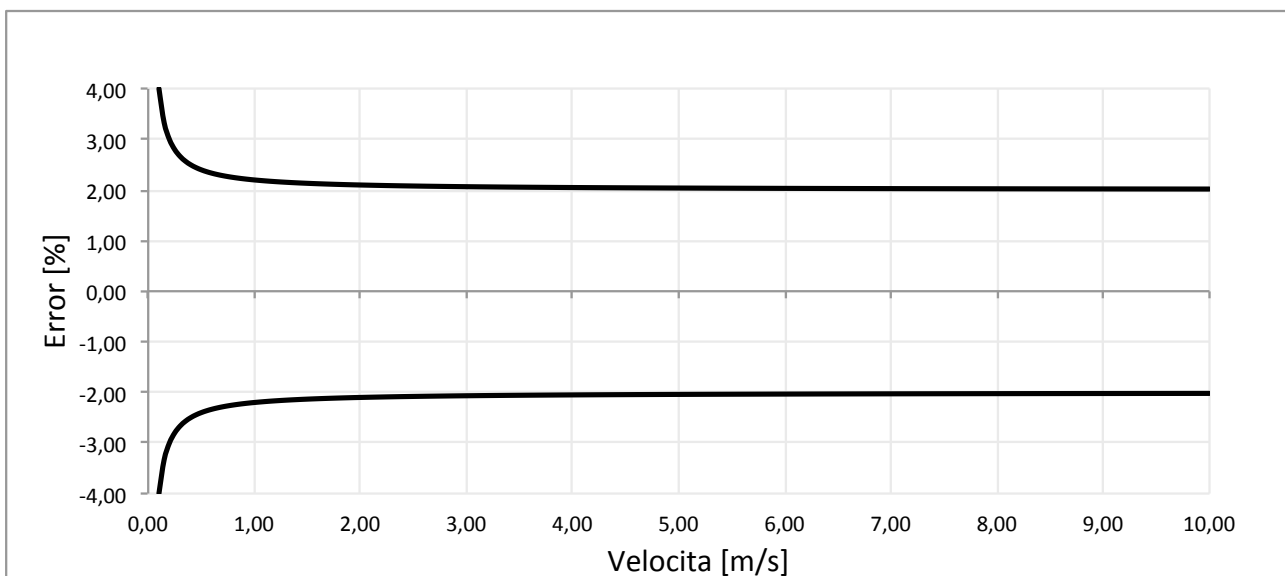

# SENSOR MUT1222

Electromagnetic  
flowmeter

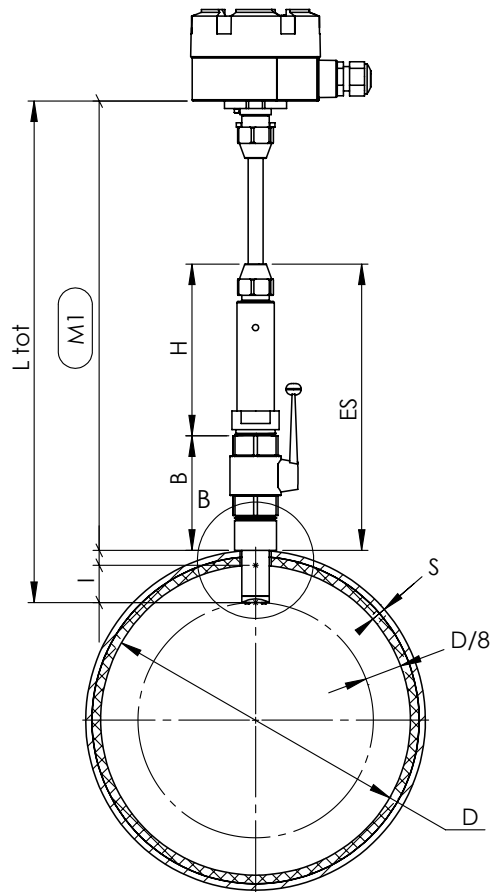

- D:** Internal diameter
- S:** Pipe wall thickness (lining included)
- B:** Dead length
- H:** Housing dimension
- Ltot:** Instrument length
- ES:** Standard dimension (Euromag original parts)
- I:** Insertion depth =  $D/8$
- M1:** Insertion control dimension

$$M1 = L_{tot} - S - (D/8)$$

- **Size S:**  
 $M1 = 403 - S - (D/8)$
- **Size M:**  
 $M1 = 674 - S - (D/8)$
- **Size L:**  
 $M1 = 916 - S - (D/8)$

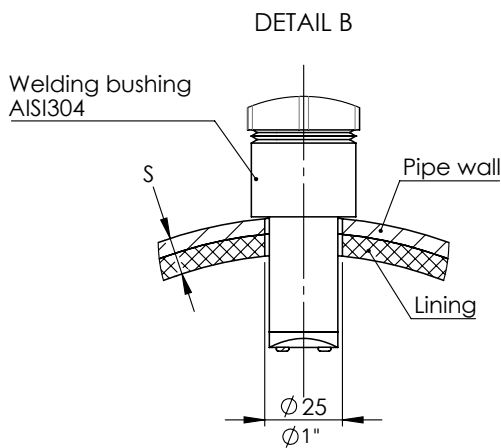

| Size | Min Pipe Diameter |        | Max Pipe Diameter |        |
|------|-------------------|--------|-------------------|--------|
|      | DN                | Inches | DN                | Inches |
| S    | 50                | 2"     | 600               | 24"    |
| M    | 200               | 8"     | 1600              | 64"    |
| L    | 450               | 18"    | 2600              | 104"   |

# SENSOR MUT1222

Electromagnetic  
flowmeter

**Size S:**  
**M1 = 403 - S - (D/8)**

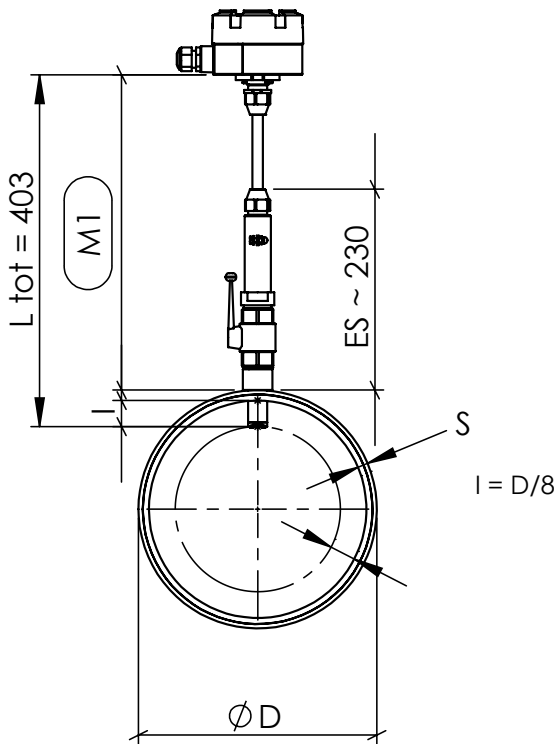

**Size M:**  
**M1 = 674 - S - (D/8)**

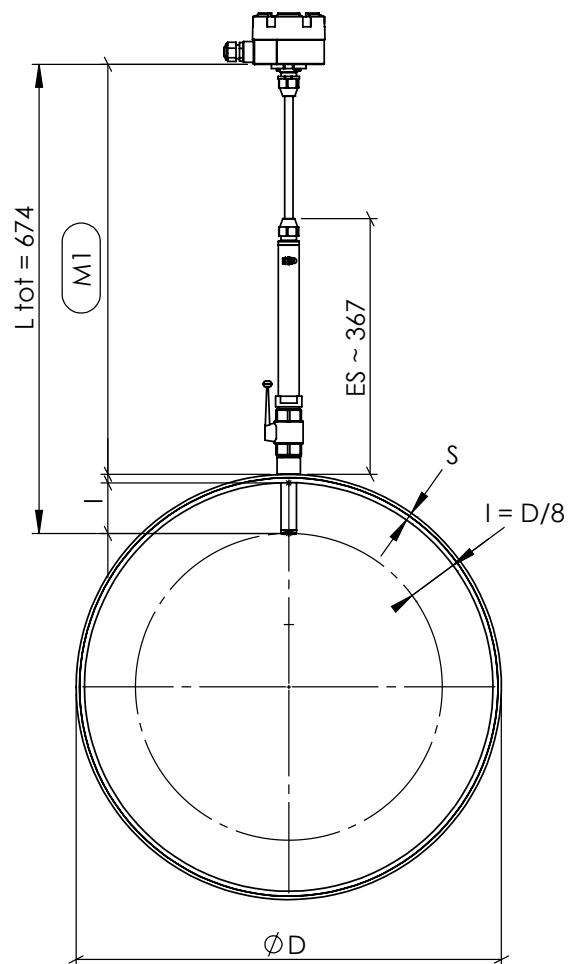

# SENSOR MUT1222

Electromagnetic  
flowmeter

Size L:  
M1 = 916 - S - (D/8)

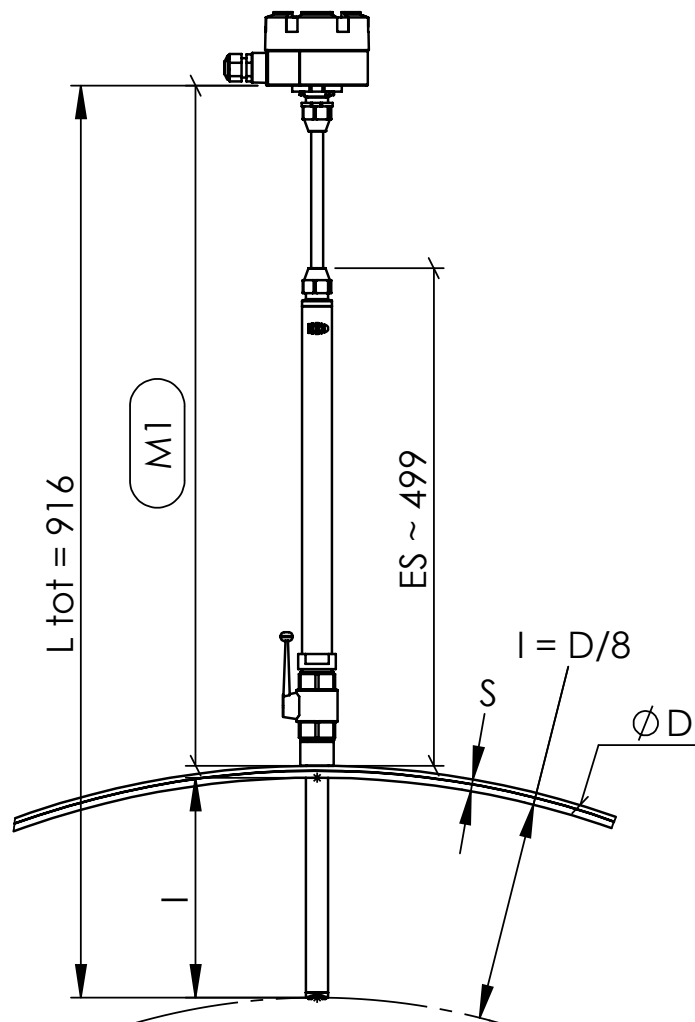



*Measure > Sense > Innovate*



**EUROMAG**  
INTERNATIONAL

*Measure > Sense > Innovate*



**EUROMAG INTERNATIONAL Srl**

Via della Tecnica, 20 - 35035 Mestrino (Padova) Italia  
Tel. +39 049.9005064 - Fax +39 049.9007764

[www.euromag.com](http://www.euromag.com) - [www.euromagdata.com](http://www.euromagdata.com)  
[euromag@euromag.com](mailto:euromag@euromag.com)