



EUROMAG
INTERNATIONAL



Wall-Mount Ultrasonic Flow Meter
EUROSONIC 2000

TD 203-0-ENG 

User Manual

READ AND KEEP THESE INSTRUCTIONS



1. INTRODUCTION	7
1.1 Preface	7
1.2 Features	7
1.3 Flow measurement principle	8
1.4 Packaging list	8
1.5 Optional parts	9
1.6 Typical applications	9
1.6.1 Applications sorted by industry / process	9
1.7 Product identification	9
1.8 Specifications	10
2. INSTALLATION AND MEASUREMENT	13
2.1 Unpacking	13
2.2 Installation considerations	13
2.2.1 Mounting the main unit	13
2.2.2 Installing transducers	13
2.2.3 Distance from main unit to transducer	14
2.2.4 Cables	14
2.2.5 Power supply wiring	14
2.2.6 Other electrical connections	14
2.3 Power up	15
2.4 Keypad	16
2.5 Menu windows	16
2.6 Menu window list	17
2.7 Steps to configure the parameters	18
2.8 Transducer mounting allocation	19
2.9 Transducers wiring	20
2.10 Transducers installation	20
2.11 Installation check-up	21
2.11.1 Signal strength	21
2.11.2 Signal quality	22
2.11.3 Total transit time and delta time	22
2.11.4 Transit time ratio	22

3. HOW TO**23**

3.1	How to check if the instrument works properly	23
3.2	How to check the liquid flowing direction	23
3.3	How to change units systems	23
3.4	How to select a flow rate unit	23
3.5	How to use the totalizer multiplier	24
3.6	How to turn on / off the totalizers	24
3.7	How to reset the totalizers	24
3.8	How to restore the factory default setups	24
3.9	How to use the damper to stabilize the flow rate	24
3.10	How to use the low-flow cut off function	24
3.11	How to conduct zero calibration	24
3.12	How to change the scale factor	25
3.13	How to use the password locker	25
3.14	How to use the keypad locker	25
3.15	How to use scheduled data output	25
3.16	How to use 4-20ma current loop output	25
3.17	How to output analogue voltage signal	26
3.18	How to use the frequency output	26
3.19	How to use the totalizer pulse output	26
3.20	How to produce an alarm signal	27
3.21	How to use the oct output	28
3.22	How to use the relay output	28
3.23	How to use the built-in buzzer	28
3.24	How to modify the built-in calendar	28
3.25	How to adjust the lcd	29
3.26	How to use the RS232 serial interface	29
3.27	How to view the totalized flow	29
3.28	How to connect analogue input signals	29
3.29	How to compensate the flow not measured during offline	30
3.30	How to use the working timer	30
3.31	How to use the manual totalizer	30
3.32	How to use the batch process controller	30
3.33	How to calibrate the analogue output	30
3.34	How to check the ESN	31

4. MENU WINDOW DETAILS**33**

5. TROUBLESHOOTING **45**

5.1 Introduction	45
5.2 Power-on errors	45
5.3 Working status errors	46
5.4 Other problems and solutions	47

6. COMMUNICATION PROTOCOL **49**

6.1 RS232 connector pin-out	49
6.2 RS232 wiring	50
6.3 Communication protocol	50
6.3.1 Basic commands	50
6.3.2 Protocol prefix usage	52
6.4 The M command and the ASCII codes	53
6.5 Programming examples	53

**7. MEASUREMENTS OF THERMAL AND OTHER
PHYSICAL PARAMETERS** **55**

7.1 Introduction	55
7.2 Wiring analogue inputs	55
7.3 Thermal energy measurement	56
7.4 Configure analogue measurement ranges	57
7.5 Read input analogue values from a network computer	57

8. WARRANTY AND SERVICE **59**

8.1 Warranty	59
8.2 Service	59

9. APPENDIX

61

9.1	Wiring diagram and outline drawings	61
9.2	Clamp-on transducer installation guide	63
9.2.1	Choose installation method	63
	V-method installation	63
	Z-method installation	63
	W-method installation	63
9.2.2	Transducer spacing	63
9.2.3	Prepare the pipe surface	64
9.2.4	Prepare the transducers	64
9.2.5	Install the transducers	64
9.2.6	Fine tune the installation	65
9.3	Standard pipe dimensions	65
9.4	Sound speed tables	66

1. INTRODUCTION

1.1 PREFACE

The wall-mount product family is designed to be installed in a fixed location for long-term flow measurement.

The flow meter is based on transit-time flow measurement principle. It measures the flow rate of liquid in a closed pipe by using a pair of clamp-on or wetted ultrasonic transducers. In general, the liquid should be full in the pipe, and should contain no or small amount of particles or air bubbles. Examples of applicable liquids are: water (hot water, chilled water, city water, sea water, etc.); sewage; oil (crude oil, lubricating oil, diesel oil, fuel oil, etc.); chemicals (alcohol, acids, etc.); waste water; beverage, liquid food, solvents and other liquids.

The utilizes state-of-the-art technologies such as advanced signal processing, low-voltage transmitting, small signal receiving, self-adaptation, the latest electronics, etc., to achieve high accuracy and reliable performance. Besides, the EUROSonic 2000 product provides versatile output interfaces, both analogue and digital, which can be easily used by a host computer or a flow controller.

1.2 FEATURES

- Better than 1% linearity.
- $\pm 0.2\%$ of repeatability.
- $\pm 1\%$ of accuracy at velocity above 0.6ft/s (0.2m/s).
- Positive / negative / net flow totalizer.
- Proprietary low-voltage transmission and self-adaptation technologies.
- Anti-interference design.
- Dual CPU. 100 Pico-second time measurement resolution.
- Operates with all Euromag transducers.
- Die-cast aluminium weather-resistant enclosure (standard version).
- Able to measure electrically conductive and non-conductive liquids.
- RS-232 interface. Complete communication protocol for instrument networking.
- Can be used as a flow RTU.
- Up to 5 channel 12 bits analogue 4-20mA input
- 1 channel programmable 4-20mA output
- 2 channel programmable digital output (isolated OCT and Relay)
- Frequency output.
- Internal batch process controller.
- 2x20 letters backlight LCD display. 4x4-key, tactile-feedback membrane keypad.

1.3 FLOW MEASUREMENT PRINCIPLE

The ultrasonic flow meter is designed to measure the velocity of liquid within a closed conduit. It uses the well-know transit-time measurement principle, plus our proprietary signal processing and ultrasonic transeiving technologies.

As shown in Figure 1, they utilize a pair of ultrasonic transducers which are mounted on the pipe upstream and downstream respectively. Each transducer functions as both ultrasonic transmitter and receiver. The main unit operates by alternately transmitting and receiving a coded burst of sound energy between the two transducers. The transit-times in the upstream direction as well as in the downstream direction are measured. The difference of the two transit times is directly and exactly related to the velocity of the liquid in the pipe.

TRANSIT TIME FLOW MEASUREMENT PRINCIPLE

$$V = \frac{MD}{\sin 2\theta} \times \frac{\Delta T}{T_{up} \cdot T_{down}}$$

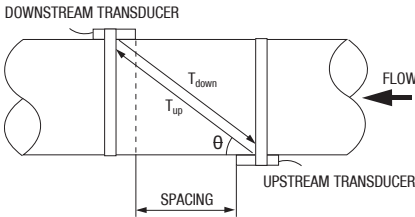

f. 1

REFERENCES

θ	is the angle between the sound path and the flow direction
M	is the number of times the sound traverses the flow
D	is the pipe diameter
T_{up}	is the time for the beam travelling from upstream the transducer to the downstream transducer
T_{down}	is the time for the beam travelling from the downstream transducer to the upstream transducer
$\Delta T = T_{up} - T_{down}$	

The flow rate is then computed by combining the velocity information with pipe parameters and a scale factor. The scale factor is normally determined by calibration in factory.

Three types of transducers can be used with the main unit in order to cover the range of diameters from 15 to 6000mm. The transducers can be mounted in V-method where the sound transverses the pipe fluid twice, or in W-method where the sound transverses the pipe fluid four times, or in Z-method where the transducers are mounted on opposite sides of the pipe and the sound crosses the pipe fluid once. The selection of the mounting methods depends on pipe and liquid characteristics.

1.4 PACKAGING LIST

• EUROSONIC 2000 main unit,	
240VAC/8-36VDC	1 unit
• EST-M1-type clamp-on transducer	
for 2"~28" pipe	1 pair
• Dedicated shielded transducer cable	5 Meters
• Potting Mix, Silicon compound	1 tube
• Clamp-on fixture	1 set
• Couplant	1 unit
• User's Manual	1 unit
• 4-20mA Analogue Output Module	1 channel
• Relay Output Module	1 channel

1.5 OPTIONAL PARTS

- EST-S1 -type clamp-on transducer for small pipe (0.5"~4")

- EST-L1 -type clamp-on transducer for large pipe (12"~240")

- Analogue Input Modules (3 channels)

1.6 TYPICAL APPLICATIONS

The flow meter can be applied to a wide range of pipe flow measurements. Applicable liquids include pure liquids as well as liquid with small quantity of tiny particles. Examples are:

- Water (hot water, chilled water, city water, sea water, waste water, etc.);
- Sewage with small particle content;
- Oil (crude oil, lubricating oil, diesel oil, fuel oil, etc.);
- Chemicals (alcohol, acids, etc.);
- Plant effluent;
- Beverage, liquid food;
- Ultra-pure liquids;
- Solvents and other liquids

1.6.1 APPLICATIONS SORTED BY INDUSTRY / PROCESS

- Water and waste water management;
- Water and waste water treatment plants;
- Power plants, such as nuclear power plants and hydraulic power plants;
- Mining and metallurgy plants;
- Petroleum process monitoring and control;
- Chemical process monitoring and control;
- Pulp and paper process monitoring and control;
- Food and beverage processing;
- Marine maintenance and operation;
- Pipeline leakage detection;
- HVAC, hydronic balancing;

- Energy supply and production systems;
- Flow measurement networking.

1.7 PRODUCT IDENTIFICATION

Each set of the series flow meter has a unique product identification number or ESN (electronic serial number) written into the software that can only be modified with a special tool by the manufacturer. In case of any hardware failure, please provide this number which is located on menu window M61 when contacting the manufacturer.

1.8 SPECIFICATIONS

Main Unit	
Linearity	Better than $\pm 1\%$.
Accuracy	$\pm 1\%$ of reading at rates >0.6 ft/s (0.2m/s). Assume a fully developed flow profile.
Repeatability	$\pm 0.2\%$.
Velocity	$\pm 0.03 \sim \pm 105$ ft/s ($\pm 0.01 \sim \pm 30$ m/s), bi-directional
Measurement Period	0.5s
Display	LCD with backlight. 2x20 letters.
Keypad	4x4-key membrane keypad with tactile feedback
Units	English (U.S.) or metric.
Outputs	Analogue output: 4-20mA or 0-20mA current output. Impedance 0~1k Ω . Accuracy 0.1%. Isolated OCT output: for frequency output (0~9,999Hz), alarm driver, or totalizer pulse output, ON/OFF control, etc. Relay output 1A@125VAC or 2A@30VDC. For ON/OFF control, alarm driver, totalizer output, etc. Internal Alarm (Buzzer): user programmable. External Alarm Driver: alarm signal can be transmitted to Relay or OCT output terminals to drive an external alarm. RS-232 serial port.
Input	Five channel 4-20mA current inputs for signals such as temperature, pressure, liquid level, and etc.. Accuracy 0.1%. Two of the five input channels are wired to terminal blocks. The remaining three channels are optional.
Others	Capable of offline compensation for flow totalizer, automatic / manual selectable. Self-diagnosis. Automatically record the following information: <ul style="list-style-type: none"> • The totalizer data of the last 64 days / 64 months / 5 years; • The power-on time and corresponding flow rate of the last 64 power on and off events. Allow manual or automatic flow loss compensation • The instrument working status of the last 64 days
Enclosure	Die-cast aluminum enclosure. Protection Class: IP65 (NEMA 4X). Weather-resistant. Size: 9.88"x7.56"x3.15" (251x192x80mm3) for standard version
Transducer	
Clamp-on	S1-type: for pipe size 1"~4" (DN30~DN100mm) M1-type: for pipe size 2"~28"(DN50~DN700mm) L1-type: for pipe size 11"~240"(DN300~DN6,000mm)

Liquids

Liquid Types

Virtually all commonly used clean liquids.

Liquids with small quantity of tiny particles may also be applicable.

Particle size should be less than 75um, particle concentration less than 10,000ppm.

Liquids should contain no or very minor air bubbles.

Examples are chilled/hot water, sea water, waste water, chemical liquids, oil, crude oil, alcohol, beer, etc.

Liquid Temp

32°F - 212°F (0°C - 100°C) for clamp-on transducer.

Higher temperatures can be accommodated. Consult the manufacturer for assistance.

32°F - 302°F (0°C - 150°C) for wetted transducer.

Suspension

< 10,000ppm and particle size less than 80um.

concentration

May contain very small amount of air bubbles.

Pipe

Pipe Size

1" ~ 240" (DN25mm ~ DN6,000mm).

Pipe Material

All metals, most plastics, fiber glass, etc. Allow pipe liner.

Pipe Straight run

15D in most cases, 30D if a pump is near upstream, where D is pipe diameter.

Cable

Shielded transducer cable. Standard length 15' (5m). Can be extended to 1640' (500m). Contact the manufacturer for longer cable requirement.

Cable should not be laid in parallel with high-voltage power lines, neither should it be close to strong interference source such as power transformers.

Environment

Temperature

Main unit: 14°F ~ 158°F (-10°C ~ 70°C)

Clamp-on transducer: -22°F ~ 212°F (-30°C ~ 100°C)

Humidity

Main unit: 85% RH

Transducer: water-submersible, water depth less than 10' (3m)

Power

AC 110 V; AC: 240V; DC: 8VDC~36V to be defined at order stage. Power consumption: < 2W

Weight

Standard main unit: 6.6lb (3kg)

2. INSTALLATION AND MEASUREMENT

2.1 UNPACKING

Please unpack the shipping box and check the parts and documents against the packing slip. If there is something missing, the device is damaged, or something is abnormal, please contact us immediately and do not proceed with the installation.

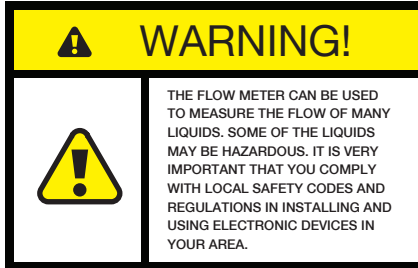

2.2 INSTALLATION CONSIDERATIONS

This section provides guidelines for installing the main unit (electronics enclosure) and its transducers.

2.2.1 MOUNTING THE MAIN UNIT

The main unit electronics (standard version) are housed in an IP65 (NEXA 4X) weather-resistant and dust-tight enclosure. Therefore, the main unit can be installed indoors and outdoors. Usually, it is mounted in a meter shed or on a location where one can easily access for meter testing and servicing. Please refer to *Appendix 9.1* for the enclosure dimensions.

2.2.2 INSTALLING TRANSDUCERS

First, you need to select a proper installation site. For this, one usually needs to consider the accessibility of the location, operating space needed for the installation, safety code compliance, etc. In addition, flow and pipe conditions near the installation site are also very important. Please refer to *section 2.8* for site selection details.

Then, follow the installation guidelines given in *Appendix 9.2* for installing clamp-on transducers.



2.2.3 DISTANCE FROM MAIN UNIT TO TRANSDUCER

In general, the closer the transducer to the main unit, the better the signals. All major cable suppliers can supply up to 1640ft (500m) long transducer cable as per specifications.

2.2.4 CABLES



The flow meter utilizes a double-balanced driving technique for high performance ultrasonic transmission and receiving. It requires twisted shielded cable for the transducer. We recommend to use the cable supplied by the manufacturer. If you want to do the transducer cabling yourself please contact the manufacturer in advance.

Try not route the transducer cable along with high current AC lines. Avoid strong interference sources. Make sure the cables and cable connections are protected from weather and corrosive conditions.

 WARNING!	
	BE CAREFUL ABOUT THE POWER SUPPLY TYPE OF YOUR FLOW METER AND THE POWER SUPPLY WIRING! CONNECTING TO A WRONG TYPE POWER SOURCE OR IMPROPER CONNECTION OF LINE POWER COULD DAMAGE THE FLOW METER. IT MAY ALSO CAUSE HAZARDOUS VOLTAGE AT ENCLOSURE, THE TRANSDUCER, FLOW CELL, AND ASSOCIATED PIPING.

Open the flow meter enclosure. On the lower right corner (refer to the figures in Appendix 9.1), you should see three terminal blocks which pins are labelled as 11, 12 and 13. Normally, pin 13 should be connected to your Earth ground. Make sure your Earth ground is good. Pins 11 and 12 should be connected to Neutral and Line, respectively.

If 8-36VDC power source is used, its positive lead and negative lead should be connected to pin 24 and 23 respectively.

 WARNING!	
	THE TRANSDUCERS MAY HAVE STATIC CHARGES ACCUMULATED DURING TRANSPORTATION. BEFORE CONNECTING THE TRANSDUCERS TO THE MAIN UNIT, PLEASE DO DISCHARGE THE TRANSDUCERS IN A SAFE AREA BY SHORTING THE CENTRE CONDUCTOR OF THE TRANSDUCER CABLE CONNECTORS TO THE METAL SHIELD OF THE CONNECTOR.

NOTE	
	WITH 8-36 V DC POWER SUPPLY THE 4-20MA OUTPUT MAY NOT BE AVAILABLE, EXCEPT SPECIAL INSTRUCTION WAS GIVEN WHEN THE ORDER WAS PROCESSED.

Please refer to *Appendix 9.1* for more wiring information.

2.2.5 POWER SUPPLY WIRING

The user normally selects the type of power supply when the order is placed. There are three types of power supply options, 110VAC, 220VAC and 8-36VDC. You must make sure the power supply type of your flow meter matches the power source to which the flow meter will be connected.

2.2.6 OTHER ELECTRICAL CONNECTIONS

Wiring RS232 Port

Refer to *sections 6.1, 6.2* and *Appendix 9.1* for details.

Wiring 0/4-20mA Output

Using standard twisted-pair wiring. Refer to *Appendix*

9.1 for details.

Wiring 0/4-20mA Inputs

There are five analogue input channels which can be used to accommodate five channels of analogue input signals. Two of them are wired to terminal blocks (pin 65, 64 and 63). You can assign temperature, pressure and other physical signals to those channels. An internal 24VDC is provided for loop-powered transmitters.

Using standard twisted-pair wiring. Refer to *Chapter 7* for details.

Wiring Alarms

Using standard twisted-pair wiring. Refer to *sections 3.21 and 3.22* for details.

2.3 POWER UP

The flow meter does not have power ON/OFF switch. When it is connected to power, it will start to run automatically.



After the power is turned on, the flow meter will run a self-diagnostic program, checking first the hardware and then the software integrity. If there is any abnormality, corresponding error messages will be displayed. (Please refer to *chapter 5* for error code explanations.)

After successful internal checks, the flow meter will display menu window #01 (short for M01), or

the menu window which was active at last power off. It will also start the measurements by using the parameters configured last time by the user or by the initial program.

The flow measurement program always operates in the background of the user interface. This means that the flow measurement will keep running regardless of any user menu window browsing or viewing. Only when the user enters new pipe parameters will the flow meter change measurement to reflect the new parameter changes.

When the power is turned on or new pipe parameters are entered, the flow meter will enter into a self-adjusting mode to adjust the gain of the receiving circuits so that the signal strength will be within a proper range. By this step, the flow meter finds the best system gain which matches the pipe material and fluid type. The user will see the progress by the number s1, s2, s3 and s4, located on the upper left corner of the LCD display. If the self-adapting process is completed successfully, letter “#R” will be displayed.

When the user adjusts the position of the installed transducers, the flow meter will re-adjust the signal gain automatically.

Any user-entered configuration value will be stored in the NVRAM (non-volatile memory), until it is modified by the user.

2.4 KEYPAD

The keypad of the flow meter has 16 keys (Figure 2).

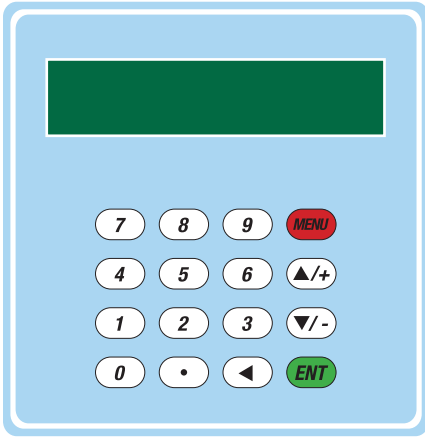

f. 2

Keys 0 ~ 9 and . are keys to enter numbers.

Key ▲/+ is the going UP key when the user wants to go to the upper menu window. It also works as “+” key when entering numbers.

Key ▼/- is the going DOWN key when the user wants to go to the lower menu window. It also works as the “-” key when entering numbers.

Key ◀ is the backspace key when the user wants to go left or wants to backspace the left character that is located to the left of the cursor.

Key ENT is the ENTER key for any input or selections.

Key MENU is the key for the direct menu window jump over. Whenever the user wants to proceed to a certain menu window, the user can press this key followed by a 2-digit number.

The MENU key is shortened as the ‘M’ key hereafter when referring to menu windows.

Key-pressing induced beep sound can be enabled / disabled in menu window M77.

2.5 MENU WINDOWS

The flowmeter user interface comprises about 100 independent menu windows that are numbered by M00, M01, M02, ..., M99, M+0, M+1, etc.

There are two methods to visit a menu window:

1) Direct jump in. Simply press the MENU key followed by a 2-digit number. For example, if you want to visit menu window M11 for pipe outer diameter, press the following three keys consecutively, MENU 1 1 .

2) Press the ▲/+ or ▼/- key. Each time of the ▲/+ key pressing will lead to the lower-numbered menu window. For example, if the current window is on M12, the display will go to window M11 after the ▲/+ key is pressed once.

You do not need to remember all the menu windows. Just remember the most commonly used window numbers and the approximate window number of some uncommonly used windows would be sufficient. You can always use ▲/+ and ▼/- keys to find the right window.

There are three different types of menu windows:

1) Menu windows for number entering, e.g., M11 for setting up pipe outer diameter.

2) Menu windows for option selection, e.g., M14 for the selection of pipe materials.

3) Results display windows, e.g., window M00 for displaying flow rate, etc.

For number entering windows, the user can directly press the digit keys if the user wants to modify the value. For example, if the current window is on M11, and the user wants to enter 219.2345 as the pipe outer diameter, then, the flowing keys should be pressed: **2 1 9 . 2 3 4 5 ENT**.

For option selection windows, the user should first press the **ENT** key to get into option selection mode. Then, use **▲/▶**, **▼/◀**, or digit key to select the right option. Consequently, press the **ENT** to make the selection.

For example, assume your pipe material is stainless steel and you are currently on menu window M14 which is for the selection of pipe materials (if you are on a different window, you need to press **NEW** **1 4** first in order to enter into the M14 window.) You need to press the **ENT** key to get into the option selection mode. Then, either press the **▲/▶** and **▼/◀** keys to make the cursor on the line that displays “1. Stainless Steel”, or press the **1** key directly. At the end, press **ENT** again to make the selection.

Generally, the **ENT** key must be pressed to get into the option selection mode for option modifications. If the “Locked M47 Open’ message is indicated on the bottom line of the LCD display, it means that the modification operation is locked out. In such cases, the user should go to M48 to have the instrument unlocked before any further modification can be made.

2.6 MENU WINDOW LIST

M00~M09 windows for the display of the instantaneous flow rate, net totalizer value, positive totalizer value, negative totalizer value, instantaneous flow velocity, date time, current analogue input values, current working status, etc.

M10~M29 windows for entering system parameters, such as pipe outer diameter, pipe wall thickness, liquid type, transducer type, transducer installation method, etc. Transducer installation spacing is then calculated according to those parameters and displayed on one of the windows.

M30~M38 windows for flow rate unit selection and totalizer configuration. User can use these windows to select flow rate unit, such as cubic meter or liter, as well as to turn on / off each totalizer, or to reset the totalizers.

M40~M49 windows for setting response time, zeroing / calibrating the system, locking / unlocking keypad, changing network address ID, password, etc.

M50~M89 windows for digital and analogue outputs, such as scheduled output, RS232 output, relay output, analogue current loop output, LCD, frequency output, alarm output, analogue inputs. Besides, there are also windows for configuring analogue inputs, date / time, and day/month/year accumulator.

M90~M94 windows for displaying diagnostic data, including the installation triplet. Those data are very useful when doing a more accurate measurement.

M95 Upon entering into this window, the circular display function is started automatically. The following windows will be displayed one by one, each window will stay for about 4 seconds: M95 ->M00 -> M01 -> M02 -> M03 -> M04 -> M05 -> M06 -> M07 -> M08 -> M09 -> M90 -> M95.

M+0~M+9 windows for some additional functions, including a single precision calculator, display of the total working time, and display of the time and the flow rate when the device is turned on and turned off.

Other menu windows are used for factory debugging.

For detailed explanation of the above windows please refer to *chapter 3 "How to"* and *chapter 4 "Menu Window Details"*.

2.7 STEPS TO CONFIGURE THE PARAMETERS

In order to make the flowmeter work properly, the user must follow the following steps to configure the system parameters:

1) Pipe size and pipe wall thickness

For standard pipe, please refer to *Appendix 9.4* for outer diameter and wall thickness data. For non-standard pipe, the user has to measure these two parameters.

2) Pipe materials

For non-standard pipe material, the sound speed of the material must be entered. Please refer to *Appendix 9.5* for sound speed data.

For standard pipe materials and standard liquids, the sound speed values have already been programmed into the flow meter, therefore there is no need to enter them again.

3) Liner material, its sound speed and liner thickness, if there is any liner.

4) Liquid type (for non-standard liquid, the sound speed of the liquid should be entered.)

5) Transducer type.

6) Transducer mounting methods (the V-method and Z-method are the common methods)

7) Check the transducer distance displayed on window M25 and install the transducers accordingly.

Example: For standard (commonly used) pipe materials and standard (commonly measured) liquids, the parameter configuration steps are as following:

1) Press keys **MENU** **1** **1** to enter into M11 window. Input the pipe outer diameter through the keypad and press **ENT** key.

2) Press key **▼/▶** to enter into M12 window. Input the pipe thickness through the keypad and press **ENT** key.

3) Press key **▼/▶** to enter into M14 window. Press **ENT** key to get into the option selection mode. Use keys **▲/▼** and **▼/▶** to scroll up and down to the proper pipe material, and then press **ENT** key.

4) Press key **▼/▶** to enter into M16 window. Press **ENT** key to get into the option selection mode. Use keys **▲/▼** and **▼/▶** to scroll up and down to the proper liner material, and then press **ENT** key. Select "No Liner", if there is no liner.

5) Press key **▼/▶** to enter into M20 window. Press **ENT** key to get into the option selection mode. Use keys **▲/▼** and **▼/▶** to scroll up and down to the proper liquid, and then press **ENT** key.

6) Press key **▼/▶** to enter into M23 window. Press **ENT** key to get into the option selection mode. Use keys **▲/▼** and **▼/▶** to scroll up and down to the proper transducer type, and then press **ENT** key.

7) Press key **▼/▶** to enter into M24 window. Press **ENT** key to get into the option selection mode. Use keys **▲/▼** and **▼/▶** to scroll up and down to the proper transducer mounting method, and then press **ENT** key.

8) Press key **▼/▶** to enter into M25 window. The transducer installation distance will be displayed

on the window. Based on this distance and the transducer installation method selected above, install the transducers on the pipe (refer to *Appendix 9.2* for more installation details.)

9) After installation is completed, check if the triplet (signal strength S, signal quality Q and transit-time ratio R) are in the right range. Press keys **MENU** **9** **0** to enter into M90 window for visiting S and Q and press **MENU** **9** **1** to visit R.

10) Press **MENU** **0** **1** to enter into window M01 to visit the measurement result.

2.8 TRANSDUCER MOUNTING ALLOCATION

The first step in the installation process is to select an optimal location for installing the transducers in order to make the measurement reliable and accurate. A basic knowledge about the piping and its plumbing system would be advisable.

An optimal location would be defined as a long straight pipe line full of liquid that is to be measured. The piping can be in vertical or horizontal position. The following table shows examples of optimal locations.

Principles to select an optimal location:

- 1) Pipe must be full of liquids at the measurement site.
- 2) No heavy corrosion or deposition inside of the pipe.
- 3) Must be a safe location.
- 4) The straight pipe should be long enough to eliminate irregular-flow-induced error. Typically, the

length of the straight pipe should be 15 times of the pipe diameter. The longer the better.

The transducers should be installed at a pipe section where the length of the straight pipe at upstream side is at least 10D and at downstream side is at least 5D, where D stands for pipe outer diameter.

5) If there are flow disturbing parts such as pumps, valves, etc. on the upstream, the straight pipe length should be increased (refer to figure 3 for more details.) The disturbance strength are in the following order (low to high): Single Bend -> Pipe Reduction / Enlargement -> Outflow Tee -> Same Plane Multiple Bends -> Inflow Tee -> Out of Plane Multiple Bends -> Valve -> Pump.

INSTALLATION SITE SELECTION

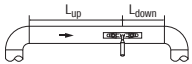
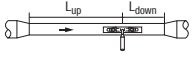
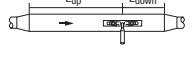
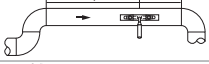
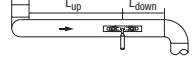
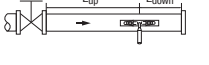
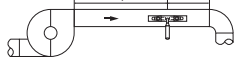
PIPING CONFIGURATION AND TRANSDUCER POSITION	UPSTREAM DIMENSION	DOWNSTREAM DIMENSION
	L _{up} X Diameters	L _{down} X Diameters
	10D	5D
	10D	5D
	10D	5D
	12D	5D
	20D	5D
	20D	5D
	30D	5D

6) Make sure that the temperature on the location does not exceed the range for the transducers. Generally speaking, the closer to the room temperature, the better.

7) Select a relatively new straight length of pipe line if it is possible. Old pipe tends to have corrosions and scale, which could affect the results. If you have to work on an old pipe, we recommend you to treat the corrosions and depositions as if they are part of the pipe wall or as part of the liner. For example, you can add an extra value to the pipe wall thickness parameter or the liner thickness parameter to take into account the deposition.

8) Some pipes may have a kind of plastic liner which creates a certain amount of gaps between liner and the inner pipe wall. These gaps could prevent ultrasonic waves from direct travelling. Such conditions will make the measurement very difficult. Whenever possible, try to avoid this kind of pipe. If you have to work on this kind of pipe, try our plug-in transducers that are installed permanently on the pipe by drilling holes on the pipe while liquid is running inside.

9) When select the measurement site, you may need to consider where to mount the flow meter main unit. Normally, the EUROSONIC 2000 electronics are housed in a weather-resistant enclosure. It can be mounted in a meter shed, or a location that allows easy access to the flow meter for programming and servicing.

10) When select the measurement site, you may also need to consider how to install the transducers. Make sure you have enough spatial space for easy operation.

2.9 TRANSDUCERS WIRING

Since the flowmeter utilizes balanced topology for high-performance ultrasonic transmitting and receiving, it is recommended to use high-frequency twisted cable with shielding as the transducer cable in order to guarantee the signal quality. Please refer to *section 2.2* and *Appendix 9.1* on how to wire transducers to the flow meter terminals.

2.10 TRANSDUCERS INSTALLATION

The transducers used by the flowmeter series ultrasonic flow meter are made of piezoelectric crystals both for transmitting and receiving ultrasonic signals through the wall of liquid piping system. The measurement is realized by measuring the travelling time difference of the ultrasonic signals. Since the difference is very small, the spacing and the alignment of the transducers are critical factors to the accuracy of the measurement and the performance of the system. Meticulous care should be taken for the installation of the transducers.

Clamp-on transducer installation steps:

1) Locate an optimal position where the straight pipe length is sufficient (see the previous section), and where pipes are in a favourable condition, e.g., newer pipes with no rust and ease of operation.

2) Calculate the transducer spacing. Just enter the pipe, fluid and transducer information through menu M11 to M24, the flow meter will calculate the transducer spacing automatically. The value will be shown in M25. Marking the transducer installation spots on the pipe according to this spacing value.

3) Clean any dust and rust on the spot where the transducers are to be installed. For a better result,

polishing the pipe outer surface with a sander is strongly recommended.

4) Apply adequate ultrasonic coupling (grease, gel or Vaseline) onto the transducer surface as well as to the installation area on the pipe surface.

5) Strap on the transducers using clamp fixture. If the pipe is metal, no need to use clamp fixture since the transducer has magnetic built-in. Make sure there is no gap between the transducer surface and the pipe surface.

6) Fine tune transducer position until the triplet, signal strength S, signal quality Q and transit-time ratio R, have the best readings and those reading are in their operational ranges ($S \geq 60$, $Q \geq 60$ and $97\% \leq R \leq 103\%$). It is even better if you can tune those readings into their optimal ranges ($S \geq 80$, $Q \geq 80$ and $99\% \leq R \leq 101\%$).

NOTE	
	<p>FOR HIGH VELOCITY FLOW, THE R VALUES MAY EXCEED THIS RANGE TO SOME DEGREE.</p>

For more details on clamp-on transducer installation, please refer to *Appendix 9.2*.

2.11 INSTALLATION CHECK-UP

After the completion of transducer installation, the user should check the following items: the receiving signal strength S, the signal quality Q value, the delta time (travelling time difference between the upstream and the downstream signals), the estimated liquid sound speed, the transit time ratio R, and etc. As such, one can be sure that the flow meter is working

properly and the results are reliable and accurate.

2.11.1 SIGNAL STRENGTH

Signal strength S indicates the amplitude of receiving ultrasonic signals by a 3-digit number. [000] means there is no signal detected, and [999] refers to the maximum signal strength that can be received.

NOTE	
	<p>IN THE FOLLOWING DESCRIPTIONS WHEN THERE WOULD BE NO RISK OF MISUNDERSTANDING, S VALUE IS EXPRESSED BY TWO DIGITS (00-99) FOR SIMPLICITY.</p>

Although the instrument works well when the signal strength ranges from 60 to 99, stronger signal strength should be pursued, because a stronger signal means a better result. The following methods are recommended to obtain strong signals:

- 1) If the current location is not good enough for a stable and reliable flow reading, or, if the signal strength is lower than 60, relocate to a more favourable location.
- 2) Try to polish the outer surface of the pipe, and apply more couplant to increase the signal strength.
- 3) Tenderly adjust the position of the two transducers, both vertically and horizontally, while checking the signal strength. Stop at the position where the signal strength reaches to maximum. Then, check the transducer spacing to make sure it is the same as or very close to what window M25 shows.
- 4) If the installation method is V-method and the pipe is big, you may need to try Z-method in order to get stronger signals.

2.11.2 SIGNAL QUALITY

Signal quality is indicated as the Q value in the instrument. A higher Q value would mean a higher Signal to Noise Ratio (SNR), and accordingly a higher degree of accuracy able to be achieved. Under normal pipe condition, the Q value is in the range of 60-99, the higher the better.

Causes for a lower Q value could be:

- 1) Interference from other instruments and devices nearby, such as a power frequency inverter which could cause strong interference. Try to relocate the flow meter to a new place where the interference can be reduced.
- 2) Bad sonic coupling between the transducers and the pipe. Try to polish the pipe surface again, clean the surface and apply more couplant, etc.
- 3) The selected pipe section is difficult to conduct the measurement. Relocate to a more favourable pipe line.

2.11.3 TOTAL TRANSIT TIME AND DELTA TIME

The total transit time (or travelling time) and the delta time are displayed on menu window M93. They are the primary data for the instrument to calculate the flow rate. Therefore, the measured flow rate will vary as the total transit time and delta time vary.

The total transit time should remain stable or vary in a very small range.

The delta time normally varies less than 20%. If the variation exceeds 20% in either positive or negative direction, there could be certain kinds of problems with the transducer installation. The user should check the installation for sure.



2.11.4 TRANSIT TIME RATIO

Transit-time ratio R is usually used to check whether the transducer installation is good and whether the entered pipe parameters are in consistency with their actual values. If the pipe parameters are correct and the transducers are installed properly, the transit time ratio should be in the range of 100 ± 3 %. Particularly, when the flow is stand-still, the ratio should be very close to 100%. If this range is exceeded, the user should check:

- a) If the entered pipe parameters are correct?
- b) If the actual spacing of the transducers is the same as or close to what shown on window M25?
- c) If the transducer are installed properly in the right direction?
- d) If the mounting location is good, if the pipe has changed shape, or if the pipe is too old (i.e., too much corrosion or deposition inside the pipe)?
- e) If there is any interference source inside of the pipe?
- f) If there are other aspects which do not meet the measurement requirements as recommended earlier?

3. HOW TO

3.1 HOW TO CHECK IF THE INSTRUMENT WORKS PROPERLY

Switch to menu M08 by entering    keys. If 'R' is displayed on the screen, the instrument is working properly.

If 'E' is displayed, the current loop output is over-ranged. Increasing the range setting in M57 will make the 'E' letter disappear. If you do not use current loop output, you may ignore this error.

If 'Q' is displayed, the frequency output is over-ranged. Increasing the range setting in M69 will make the 'Q' letter disappear. If you do not use frequency output, you may ignore this error.

If 'G' is displayed, the flow meter is adjusting system gain. This is normal as far as it does not last long.

If 'I' is displayed, there is no signal received. Check if the transducer cables are connected properly and transducers are clamped firmly.

If 'J' is displayed, there is hardware problem. Turn off the power, then, turn on the power again. If the problem remains, refer to *Chapter 5* for diagnosis details.

If an 'H' flashes instead, the received signal is poor.

Please refer to *Chapter 5* for diagnosis information.

3.2 HOW TO CHECK THE LIQUID FLOWING DIRECTION

Assume that transducer A is connected to the upstream terminals and transducer B is connected to the downstream terminals.

First, make sure that the instrument works properly.

Then, check the flow rate reading. If the value is positive, the direction of the flow will be from transducer A to B. Otherwise, the flow is from B to A.

3.3 HOW TO CHANGE UNITS SYSTEMS

Use menu window M30 for the selection of units systems, either English (option 0) or in Metric (option 1).

3.4 HOW TO SELECT A FLOW RATE UNIT

Use menu window M31 to select the flow rate unit, use menu window M32 to select the flow totalizer unit.

3.5 HOW TO USE THE TOTALIZER MULTIPLIER

Use window M33 to select a proper multiplying factor for the totalizers (POS, NEG and NET). Make sure that the rate of the totalizer pulse is not too fast, neither too slow. A speed of several pulses per minute is preferable.

If the totalizer multiplying factor is too small, the output pulse will be very fast and there could be a loss of pulses. The designed minimum pulse period is 500 milliseconds.

If the totalizer multiplying factor is too large, the output pulse will be very slow, which might be a problem if the master device requires fast response.



3.6 HOW TO TURN ON / OFF THE TOTALIZERS

Use M34, M35 or M36 to turn on or turn off the POS, NEG or NET totalizer, respectively.

3.7 HOW TO RESET THE TOTALIZERS

Use M37 to reset the flow rate totalizers.

3.8 HOW TO RESTORE THE FACTORY DEFAULT SETUPS

Go to window M37. Press the   Keys. This operation will erase all the parameters entered by the user and setup the instrument with factory default values.

3.9 HOW TO USE THE DAMPER TO STABILIZE THE FLOW RATE

The damper acts as a filter for a stable reading. Its damping constant is entered in window M40. Its unit is in second. If '0' is entered, that means there is no

damping. A bigger constant number brings a more stable effect. But bigger numbers will prevent the instrument from acting quickly.

A constant from 5 to 30 is commonly used for the damper value.

3.10 HOW TO USE THE LOW-FLOW CUT OFF FUNCTION

The value displayed in window M41 is the low-flow cut off. When the absolute value of the measured flow velocity is below this value, the measured velocity as well as flow rate will be replaced with '0'. This is to avoid any invalid accumulation when the actual flow is below the low-flow cut off value.

Application example: when a pump is shut down, the liquid will not stop immediately. It will keep moving (may be backward) for a little while. During this period, the totalizer should be prevented from accumulating. This can easily be done by setting the low-flow cut off velocity to a certain value, such as 0.1ft/s (0.03m/s)

The low-flow cut off operation does not affect the flow measurement when the actual flow is greater than the low-flow cut off value.

3.11 HOW TO CONDUCT ZERO CALIBRATION

When the flow in a pipe is absolutely stopped, the flow meter could still give a small non-zero flow rate reading. In order to make the measurement accurate, it is necessary to remove this "zero point" reading.

Window M42 allows us to take care of this issue. At first, the user should make sure that the liquid in the pipe is totally stopped (no velocity). Then, go to window M42 and press the  key to start the zero point setup function. Wait until the counter reading goes down to '00'.

3.12 HOW TO CHANGE THE SCALE FACTOR

A scale factor is the ratio between the 'actual flow rate' and the flow rate measured by the flow meter. It can be determined by calibration with standard flow calibration equipment. You may change the scale factor in menu window M45.

The scale factor is transducer dependent. Prior to shipment from the factory, the scale factor of a transducer pair is calibrated on a pipe with water flowing inside. If you ordered multiple pairs of transducers, be sure you entered the scale factor of the transducer pair you are using.

The scale factor is also affected by other factors such as pipe size, fluid viscosity, installation variation, etc. It is therefore recommended to do on-site calibration when accuracy is of crucial importance.

3.13 HOW TO USE THE PASSWORD LOCKER

The password locker provides a means of preventing inadvertent configuration changes or totalizer resets. When the system is locked, the user can still browse menu windows, but cannot make any modifications on the windows.

The password locking / unlocking is done in window M47. The system can be locked without a password or with a password consisted of 1 to 4 digits.

For no-password locking / unlocking, just press **ENT** key in window M47.

If the password is forgotten, please contact the manufacturer.

3.14 HOW TO USE THE KEYPAD LOCKER

First, switch to the menu window which will be displayed after the keypad is locked.

Then, press **MENU** **4** **8** to switch to menu M48. Press **ENT** and enter a 1-8 digit long password.

Password should be numerical only. Press **ENT** again to set the password. The system will return to the previously selected window automatically.

3.15 HOW TO USE SCHEDULED DATA OUTPUT

Data can be sent to RS232 serial port by a preset schedule.

The data items to be output are selected in M50. Switch to menu M50, select "ON", followed by data items, then press **ENT**. If you do not want to output data through RS232, select "OFF" in M50 and press **ENT**.

The output time, interval and last period are set in window M51. Refer to the *next chapter* for details on M51.

3.16 HOW TO USE 4-20MA CURRENT LOOP OUTPUT

The accuracy of the current loop output is better than 0.1%. It can be configured to different mode, such as 4-20mA mode, 0-20mA modem, etc. Mode selection can be made in menu M55. Refer to the *next chapter* for details on M55.

In order to use the 4-20mA output function, you need not only select the mode to be 4-20mA in M55, but also set the flow rate values which correspond to the minimum current (4mA) and the maximum current (20mA). Enter the two values in M56 and M57.

Example A: flow rate range is 0-500m³/h. Just enter 0 in M56 and 500 in M57.

Example B: flow rate range is -500-0-1000m³/h. If flow direction is not an issue for you, you may select 20-4-20mA mode in M55. Then, enter 500 in M56 and 1000 in M57. If flow direction is an issue, you may select 0-4-20mA mode in M55. This means that the current loop will output 0-4mA when flow rate

is negative and 4-20mA when flow rate is positive. Enter -500 in M56 and 1000 in M57.

You may need to calibrate and test the current loop output before using it. Just go to menu M58 and do the following:

First, connect an ammeter to the current loop output.

Press **MENU** **5** **8**, then, **ENT** to enter into menu M58.

Use **▲/▲** and **▼/▼** to display “0mA”, “4mA”, “8mA”, “16mA”, “20mA” orderly, record the corresponding reading on the ammeter. Calculate the differences between the readings and the selected ones. For instance, when 4mA is selected, the actual output current shown on the ammeter is 4.01mA. Then, the difference is 0.01mA.

If the differences are not within tolerance, calibrate the current loop (see *section 3.33*)

The present current loop output is displayed in Window M59. It changes along with flow rate change.

3.17 HOW TO OUTPUT ANALOGUE VOLTAGE SIGNAL

Connect a 2500hm/0.25W resistor across the two current loop output terminals (terminals 21 and 22). This will convert the 4-20mA current signal into 1-5V voltage signal.

3.18 HOW TO USE THE FREQUENCY OUTPUT

All the flow meters have Frequency Output functionality. This frequency output signal, which represents the flow rate, is intended to connect with other instruments.

The Frequency Output is totally user-configurable. Usually, four parameters should be configured.

Enter the lower limit of flow rate in window M68 and the higher limit of flow rate in window M69.

Enter the frequency maximum and minimum in window M67.

For example, assume that the flow rate varies in a range from 0m³/h to 3000m³/h, and the required output signal frequency should be in a range from 200Hz to 1000Hz. The user should enter 0 in M68 and 3000 in M69, and enter 200 and 1000 in window M67.

Please note that the user needs to select the frequency output option (the 13th option, “FO output”) in window M78. The user must also make the OCT hardware connection to the device which is supposed to use the frequency output signal. Refer to *Appendix 9.1* for wiring information.

3.19 HOW TO USE THE TOTALIZER PULSE OUTPUT

The flow meter is able to produce a pulse output every time when it reaches a unit flow of liquid. This pulse could be used by an external pulse counter to accumulate the flow rate.

Refer to *3.4 and 3.5* for the setup of the totalizer units and multiplier.

The totalizer pulse output can only be transmitted through OCT or relay devices. Therefore, it is necessary to configure the OCT or relay. This can be done in menu M78 and M79. Refer to the next chapter for detail on M78 and M79.

For example, assume that we need to output the POS totalizer through the relay in pulse form, and every pulse represents 0.1cubic meter of liquid flow. The following steps must be performed:

- 1) Select the Cubic Meter (m³) unit in window M32.
- 2) Select the Multiplier factor as ‘2. X0.1’ in window M33.

3) Select the output option '9. POS INT Pulse' in window M77. (INT stands for integrated or totalized)

NOTE	
	<p>THE TOTALIZER PULSE MUST BE SET PROPERLY. IT SHOULD BE NEITHER TOO LARGE NOR TOO SMALL. IF IT IS TOO LARGE (E.G., LONG PERIOD), THE OUTPUT PULSE WILL BE VERY SLOW. IF IT IS TOO SMALL (E.G., SHORT PERIOD), THE RELAY MAY ACTIVATE TOO FREQUENTLY AND ITS LIFETIME MAY BE SHORTENED. FURTHERMORE, PULSE LOSS ERROR MAY OCCUR. IT IS RECOMMEND TO SET VALUES THAT WOULD GENERATE 1 TO 60 PULSE/MINUTE. YOU CAN ADJUST THE PULSE PERIOD BY SELECTING DIFFERENT TOTALIZER MULTIPLIER FACTOR IN M33.</p>

5) Overflow occurs at the analogue outputs by 120% or more.

6) Overflow occurs at the frequency output by 120% or more.

7) The flow rate is out of the specified range, which is configured in windows M73 and M74 for Alarm #1, and in windows M75 and M76 for Alarm #2.

Example A: assume we need the Buzzer to start beeping when the flow meter is not ready in normal measurement. Switch to M77, select item "2. Abnormal Measurement State"

Example B: assume we need the Buzzer to start beeping when the flow rate is less than 300 m³/h and greater than 2000m³/h. The following setup steps would be recommended:

3.20 HOW TO PRODUCE AN ALARM SIGNAL

There are two types of hardware alarms that are available with this instrument. One is the audible alarm, and the other is the ON/OFF output signal which can drive an alarm. The audible alarm is also called Buzzer. It is generated internally and can be configured in M77. The ON/OFF output signal is generated through the OCT or relay output which is connected to an external alarm circuitry.

The triggering sources of the alarming events for both the Buzzer and the ON/OFF alarm signal could be:

- 1) There is no receiving signal.
- 2) The signal received is too weak.
- 3) The flow meter is not in normal measurement mode.
- 4) The flow direction is changed.

1) Enter flow rate lower limit 300 in M73 for #1 alarm,

2) Enter flow rate upper limit 2000 in M74 for #1 alarm,

3) Select item '6. Alarm #1' in M77.

Example C: assume we need the OCT output to activate when flow rate exceeds 100~500m³/h and the relay output to activate when flow rate exceeds 600~1000m³/h. The following setup steps would be recommended:

- 1) Enter flow rate lower limit 100 in M73
- 2) Enter flow rate upper limit 500 in M74
- 3) Enter flow rate lower limit 600 in M75
- 4) Enter flow rate lower limit 1000 in M76
- 5) Select item '6. Alarm #1' in M78
- 6) Select item '6. Alarm #1' in M79.

3.21 HOW TO USE THE OCT OUTPUT

The OCT output is an ON/OFF type, electrically isolated collector open circuit output. It is user-configurable. You can program it to be an ON/OFF type alarm signal or a totalizer pulse signal.

Notice that the Frequency Output shares the same OCT hardware. When used as Frequency Output, the OCT cannot be used for other purpose (neither alarm signal nor totalizer pulse signal).

WIRE AN EXTERNAL ALARM DEVICE TO THE FLOWMETER OCT OUTPUT

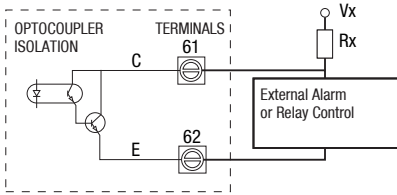

f. 4

The OCT has two wiring terminals, terminals 61 and 62. Terminal 61 is collector and terminal 62 is emitter. Be careful of the polarity. An external DC power supply Vx and an external pull-up resistor Rx are needed for using the OCT (Figure 4). Vx can be from +8VDC to +24VDC. Rx can be from 1KOhm to 10KOhm. The OCT can drive an alarm, pulse counter, frequency counter, etc. It can also be used to drive a relay, which operates a valve system, for instance.

Refer to the *next chapter* on menu M78 for OCT configuration.

3.22 HOW TO USE THE RELAY OUTPUT

The relay output is a single-pole single-throw (SPST),

normally ON output device. Its maximum operating frequency is 1Hz. Its load current is 1A at 125VAC, or, 2A at 30VDC.

WIRE AN EXTERNAL ALARM DEVICE TO THE FLOWMETER RELAY OUTPUT TERMINALS

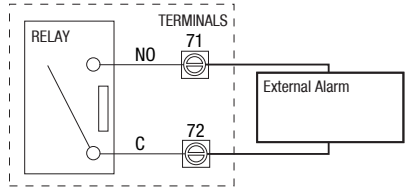

f. 5

The relay output is user-configurable and can be configured as an ON/OFF type alarm signal or a totalizer pulse signal. Its signal is sent to terminals 71 and 72, which can be connected to a remote counter or alarm device (Figure 5). Refer to the next chapter on menu M79 for relay configuration.

3.23 HOW TO USE THE BUILT-IN BUZZER

The built-in buzzer is user-configurable. It can be used as an alarm. Use M77 for setups.

3.24 HOW TO MODIFY THE BUILT-IN CALENDAR

The current date and time is displayed in menu M04 in format “yy-mm-dd hh:mm:ss”. If this is the first time you run the flow meter, please do make sure that the date and time are correct. If not, please make correction. Besides, if “daylight saving” applies in your area, you may also need to change the time accordingly.

To make changes on the date and time, press

Press **8** **1** **ENT** to switch to menu M61 and modify the settings. Use the **→** key to skip over these digits that need no modifications.

3.25 HOW TO ADJUST THE LCD

Use M70 to adjust the LCD backlight. Press **MENU** **7** **0** **ENT**. You should see “>” on the screen, which indicates that the system is ready for modification. Use **▲/▶** and **▼/◀** to select the desired option. “Always On” means that the backlight will remain on always. “Always Off” means that the backlight will remain off always. “Time=” means that the backlight will keep on for “x” seconds which should be keyed in after selecting “Time=”.

Use M71 to adjust the LCD contrast. This is necessary when the letters on the screen are not clear and the viewing angle is offset. Press **MENU** **7** **1** **ENT**. You should see “>” on the screen. Use **▲/▶** or **▼/◀** to increase or decrease the contrast.

3.26 HOW TO USE THE RS232 SERIAL INTERFACE

The flowmeter family flow meters are equipped with a RS232C standard serial interface. The RS232 interface is wired to a DB9 connector. The data rate can be set to 75-115200 Baud. Use M62 to configure this interface. Refer to *Chapter 6* for more details

You may use an external RS232-to-RS485 converter to connect the flow meter to a 485 bus.

3.27 HOW TO VIEW THE TOTALIZED FLOW

Use M82 to view the daily, monthly and yearly totalized flow.

To view the last 64 days' flow history, press **MENU** **8** **2**, then, select item 0 for “Day”. You should see the serial number and the date on the first line, and the net totalized flow for this specific day.

Note that, on the upper right corner, you may see “----”, which indicates that the system was normal during that day. If you see other characters, error occurred in that day. Please refer to *chapter 5* for error code explanation and resolution.

To view the flow for a month or a year, press **MENU** **8** **2** and select item 1 for “Month” or 2 for “Year”.

3.28 HOW TO CONNECT ANALOGUE INPUT SIGNALS

There are five analogue input channels which can be used to connect to five channels of 4-20mA signals. They are digitized and then acquired by the flow meter. The data can then be sent to a remote computer or controller through RS232 upon request. Refer to *chapter 6* for communication details.

The input analogue signal can be of pressure, temperature or other physic quantities. When analogue inputs AI1 and AI2 are connected to the “hot” and “cold” temperature sensors of a liquid thermal energy supply system, the flow meter can measurement the thermal energy consumption of the system.

Menu window M06 displays the present current and its corresponding pressure / temperature value.

The terminals assigned to these analogue inputs are (refer to *Appendix 9.1*):

AI1: 64 and 63; AI2: 65 and 63; AI3: 73 and 63; AI4: 74 and 63; AI5: 75 and 63.

AI3, AI4 and AI5 are not connected to terminals. Please contact the manufacturer if needed.

3.29 HOW TO COMPENSATE THE FLOW NOT MEASURED DURING OFFLINE

When the power is down, the flow meter will not be able to conduct flow measurement. In order to compensate the flow uncounted during the offline period, you need to enable Automatic Amending function before the flow meter is offline.

To enable the Automatic Amending function, switch to M83, press **ENT** key, then, select YES and press **ENT** again.

To disable this function, just select OFF in menu M83.

Refer to the *next chapter* for M83 details and how the uncounted flow is estimated.

3.30 HOW TO USE THE WORKING TIMER

Use the working timer to check the time that has passed with a certain kind of operation.

The working timer value is displayed in window M72.

To reset the timer, press **ENT** key and select YES.

3.31 HOW TO USE THE MANUAL TOTALIZER

Use M38 for the manual totalizer setup. Switch to M38. Press **ENT** key to start and stop the totalizer. This function can be used for flow meter calibration.

3.32 HOW TO USE THE BATCH PROCESS CONTROLLER

The flowmeter has a batch process controller built-in. It can be used for flow quantity control or the batching

of specific volumes.

This batch controller utilizes the keypad or the rising edge or falling edge of an analogue input signal as its control signal input (or triggering signal). It utilizes the OCT or relay as its output. When using analogue as the input signal, the input current must be larger than 2mA to indicate a logic "1" and 0mA to indicate a logic "0".

The user needs to select the type of input control signal in menu M80. The user also needs to select the output type to be item 8 "output as batch controller" in M78 for OCT output or in M79 for relay output.

Use M81 to enter batch value. After completion, the display will be in batch control mode and the batch controller is waiting for triggering signal. If you selected "0. Key Input" as the triggering source in M80, you may press the **ENT** key to start the batch process. Otherwise, just wait the specified triggering event is detected. Refer to the next chapter for M80 and M81 details.

3.33 HOW TO CALIBRATE THE ANALOGUE OUTPUT

In general, there is no need to calibrate the analogue output since it has been calibrated in factory. However, when conducting current loop calibration (see 3.76), if you find the current value shown in M58 differs from the actual current shown in the ammeter, you do need to recalibrate the analogue output.

Calibration steps:

First, put the flow meter into calibration mode. Press **MEM** **8** **2** **ENT**, enter password "4213068", and press **ENT** again.

Then, connect a precise ammeter to the current output loop.

Press **MENU** **▼/→** **5** **ENT** to calibrate the current loop 4mA output. Read the ammeter. If the reading is not 4mA, use **▲/←** or **▼/→** to adjust the output current until the ammeter reads 4.00mA.

Press **ENT** again to calibrate 20mA output, similar to the above step.

Press **MENU** **▼/→** **6** **ENT** to save the results in the internal non-volatile EEPROM.

3.34 HOW TO CHECK THE ESN

Each product of the flowmeter series has a unique electronic serial number (ESN) to identify itself. The user can use the ESN for instrumentation management. The ESN is displayed in window M61.

Use M+1 to view the total working time since the instrument left the factory. Use M+4 to view the total number of times the instrument has been turned on and off since the instrument left the factory.

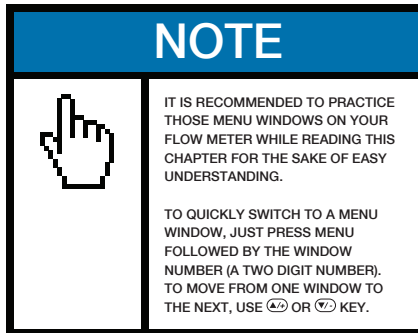

4. MENU WINDOW DETAILS



Menu window No.	Function
M00	Display flow rate and net totalizer value. If the net totalizer is turned off in M34, the net totalizer value shown on the screen is the total prior to its turn off.
M01	Display flow rate and velocity.
M02	Display flow rate and POS (positive) totalizer. Select the positive totalizer units in menu M31. If the POS totalizer is turned off, its value shown on the screen is the total prior to its turn off.
M03	Display flow rate and NEG (negative) totalizer. Select the negative totalizer units in M31. If the NEG totalizer is turned off, its value shown on the screen is the total prior to its turn off.
M04	Display the current date time and flow rate. The time setting method is found in M60.
M05	Display Instantaneous Caloric and Totalized Caloric.
M06	Display Analogue Input AI1 / AI2 current value and its corresponding temperature, pressure or liquid level value.
M07	
M08	System Error Codes Display the working condition and the system error codes. Refer to <i>Chapter 5</i> for details.
M09	Display today's total NET flow
M10	Window for entering the peripheral of the pipe. If pipe outer diameter is known, skip this menu and go to menu M11 to enter the outer diameter.
M11	Window for entering the outer diameter of the pipe. Valid range: 10 to 6000mm. Note, you just need to enter either outer diameter in M11 or pipe peripheral in M10.
M12	Window for entering pipe wall thickness. You may skip this menu and enter inner diameter in M13 instead.

Menu window No.	Function
M13	Window for entering the inner diameter of the pipe. If pipe outer diameter and wall thickness are entered correctly, the inner diameter will be calculated automatically, thus no need to change anything in this window.
M14	Window for selecting pipe material. Standard pipe materials (no need to enter the material sound speed) include: 0) carbon steel 1) stainless steel 2) cast iron 3) ductile iron 4) copper 5) PVC 6) aluminum 7) asbestos 8) fiberglass-epoxy 9) Other (need to enter sound speed in M15)
M15	Window for entering the sound speed of non-standard pipe materials
M16	Window for selecting the liner material. Select none for pipes without any liner. Standard liner materials (no need to enter liner sound speed) include: 1) Tar Epoxy 2) Rubber 3) Mortar 4) Polypropylene 5) Polystyrol 6)Polystyrene 7) Polyester 8) Polyethylene 9) Ebonite 10) Teflon 11) Other (need to enter sound speed in M17)
M17	Window for entering the sound speed of non-standard liner materials
M18	Window for entering the liner thickness, if there is a liner
M19	
M20	Window for selecting fluid type For standard liquids (no need to enter liquid sound speed) include: 0) Water 1) Sea Water 2) Kerosene 3) Gasoline 4) Fuel oil 5) Crude Oil 6) Propane at -45C 7) Butane at 0C 8) Other (need to enter sound speed in M21 and viscosity in M22) 9) Diesel Oil 10) Caster Oil 11) Peanut Oil 12) #90 Gasoline 13) #93 Gasoline 14) Alcohol 15) Hot water at 125C
M21	Window for entering the sound speed of non-standard liquids. Used only when item 8 "Other" is selected in menu M20.
M22	Window for entering the viscosity of non-standard liquids. Used only when item 8 "Other" is selected in menu M20.
M23	Window for selecting transducer type. There are 13 types: 0.Standard M 7. Not Used 1.Plug-in Type C 8. Standard-HS 2.Standard-S 9. Standard-HM 3.User Type 10. Standard-M1 4.Standard-B 11. Standard-S1 5.Plug-in Type B45 12. Standard-L1 6.Stand-L

Menu window No.	Function										
M24	<p>Window for selecting the transducer mounting methods</p> <p>Four methods can be selected:</p> <ol style="list-style-type: none"> 0. V-method (commonly used); 1. Z-method (most commonly used); 2. N-method (for small pipe. rarely used); 3. W-method (for small pipe). 										
M25	Display the transducer mounting spacing or distance										
M26	<p>Entry to store/load the system setup parameters (pipe parameters, fluid parameters, transducer parameters, etc.). Three operation methods available:</p> <ol style="list-style-type: none"> 1. Entry to Save 2. Entry to Load 3. To Browse <p>To save the current setup parameters, select "Entry to Save" and press ENT. An address number and original parameters will be displayed. Use ▲/▼ or ◀/▶ key to change address number. Press ENT again will save the current setup parameters into the selected address space.</p>										
M27	Display the cross-sectional area inside the pipe.										
M28	Entry to determine whether or not to keep the last good value when poor signal condition occurs. This function allows continued flow totalizing. YES is the factory default.										
M29	<p>Entry to set empty pipe signal threshold. When the signal strength is less than this threshold, the pipe is classified as empty pipe, and the flow meter will not totalize the flow.</p> <p>This is based on the fact that, when the pipe is empty, the transducer can still receive signal, just smaller than normal. As a result, the flow meter will show normal operation, which is not correct.</p>										
M30	Window for selecting unit system. The conversion from English to Metric or vice versa will not affect the unit for totalizers.										
M31	<p>Window for selecting flow rate unit system.</p> <p>Flow rate can be in</p> <table style="width: 100%; border: none;"> <tr> <td style="width: 50%;">0. Cubic meter short for (m3)</td> <td style="width: 50%;">5. Cubic feet (cf)</td> </tr> <tr> <td>1. Liter (l)</td> <td>6. USA liquid barrel (bal)</td> </tr> <tr> <td>2. USA gallon (gal)</td> <td>7. Imperial liquid barrel (ib)</td> </tr> <tr> <td>3. Imperial Gallon (igl)</td> <td>8. Oil barrel (ob)</td> </tr> <tr> <td>4. Million USA gallon (mgl)</td> <td></td> </tr> </table> <p>The flow unit in terms of time can be per day, per hour, per minute or per second. So there are 36 different flow rate units in total for selection.</p>	0. Cubic meter short for (m3)	5. Cubic feet (cf)	1. Liter (l)	6. USA liquid barrel (bal)	2. USA gallon (gal)	7. Imperial liquid barrel (ib)	3. Imperial Gallon (igl)	8. Oil barrel (ob)	4. Million USA gallon (mgl)	
0. Cubic meter short for (m3)	5. Cubic feet (cf)										
1. Liter (l)	6. USA liquid barrel (bal)										
2. USA gallon (gal)	7. Imperial liquid barrel (ib)										
3. Imperial Gallon (igl)	8. Oil barrel (ob)										
4. Million USA gallon (mgl)											

Menu window No.	Function
M32	Window for selecting the totalizers' unit. Available unit options are the same as those in M31.
M33	Window for setting the totalizer multiplying factor The multiplying factor ranges from 0.001 to 10000. Factory default is 1.
M34	Turn on or turn off the NET totalizer
M35	Turn on or turn off the POS totalizer
M36	Turn on or turn off the NEG totalizer
M37	1) Totalizer reset 2) Restore the factory default settings. Press the  key followed by the  key. Attention, it is recommended to make notes on the parameters before doing the restoration.
M38	Manual totalizer used for calibration. Press any key to start and press the key again to stop the totalizer.
M39	Not used,
M40	Flow rate damper setup. The damping parameter ranges from 0 to 999 seconds. 0 means there is no damping. Factory default is 10 seconds.
M41	Low flow rate (or zero flow rate) cutoff to avoid invalid accumulation.
M42	Zero calibration / Zero point setup. Make sure the liquid in the pipe is not running while doing this setup.
M43	Clear the zero point value, and restore the factory default zero point.
M44	Set up a flow bias. Generally this value should be 0.
M45	Flow rate scale factor. Keep this value as '1' when no calibration has been made.
M46	Network address identification number (IDN). Any integer can be entered except 13(ODH, carriage return), 10 (OAH, line feeding), 42 (2AH*), 38 (26H&), 65535. Every set of the instrument in a network environment should have a unique IDN. Please refer to chapter 6 for communications.
M47	System locker to avoid modification of the system parameters. Contact the manufacturer if the password is forgotten.
M48	Keypad locker to avoid any operation errors by unauthorized personnel. Contact the manufacturer if the password is forgotten.
M49	Communication tester.
M50	Window to configure the scheduled output function. To turn on the function, select YES. The system will ask for selecting the output data items. There are 15 data items available. Turn on all the items you want to output.
M51	Window to setup the time of the scheduled output function. This includes start time, time interval and lasting period. Minimum time unit is second. Maximum time interval is 24 hours.

Menu window No.	Function
M52	
M53	Used for analogue input AI5. Display the current loop value and corresponding temperature / pressure / liquid level of analogue input channel AI5.
M54	Used for analogue input AI5. Set the minimum and maximum values of temperature / pressure / liquid level which correspond to input current of 4mA and 20mA.
M55	Select the current loop (CL) mode. Available options: <ol style="list-style-type: none"> 0. 4-20mA Output Mode (set up the output range from 4-20mA) 1. 0-20mA Output Mode (set up the output range from 0-20mA) 2. RS232 controls 0-20mA (set up to control by Serial Port) 3. Turn off the current loop (turn off the current loop to save battery life. Default.) 4. 20-4-20mA Mode (set up the output range from 20-4-20mA) 5. 0-4-20mA Mode (set up the output range from 0-4-20mA) 6. 20-0-20mA Mode (set up the output range from 20-0-20mA) 7. 4-20mA Corresponding Velocity (set up the current loop output range from 4-20mA) 8. 4-20mA Corresponding Heat Flow (set up the current loop output range from 4-20mA)

The output current value is controlled by sending a parameterized command to the flow meter through its RS232 serial port. The command formats are explained in *chapter 6*. Example, if you want to output a 6mA current through the current loop, you need to select mode "0-20mA Via RS232" in menu M55 and send command "A06 (CR)" to the flow meter. This function allows the flow meter to control valve openness.

Other different current output characteristics are illustrated in the following figures. The user can select one of them according to his actual requirements. The minimum and maximum values indicated in the figure are those set in menu windows M57 and M58. In the 4-20mA and 0-20mA modes, the minimum and maximum can be a positive or negative flow value as long as the two values are not the same. In the 20-4-20mA and 20-0-20mA modes, the polarity of the actual flow reading is ignored. In 0-4-20mA mode, the minimum must be negative, and the maximum must be positive.

The last one in the following figures is for velocity output. The output current represents flow velocity.

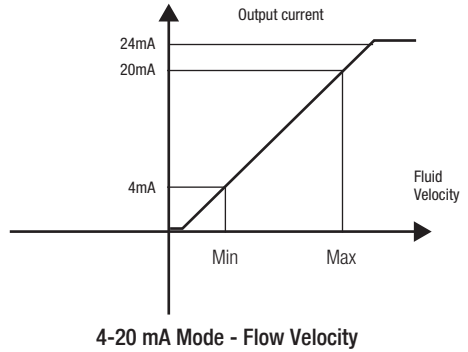
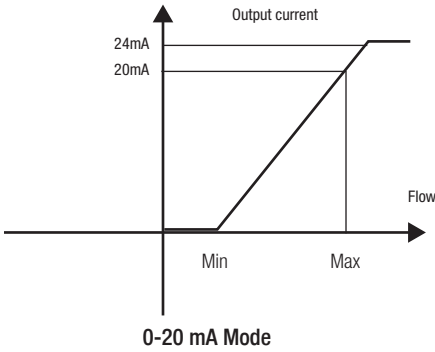
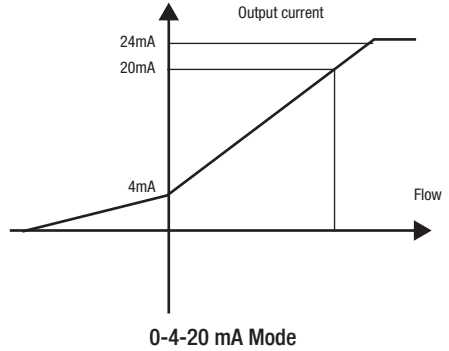
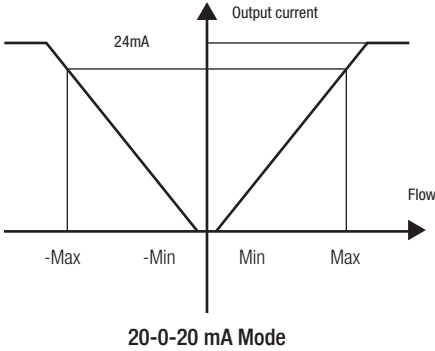
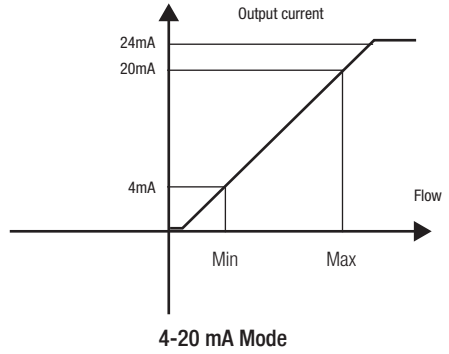
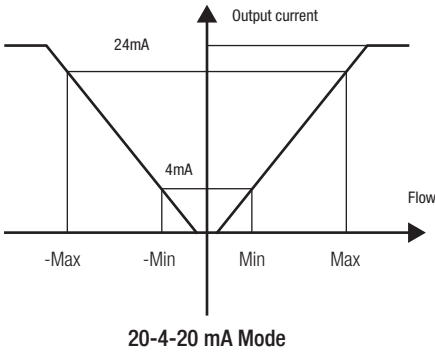

Menu window No.	Function
M56	<p>4mA or 0mA output value</p> <p>Set the flow rate value which corresponds to 4mA or 0mA output current (4mA or 0mA is determined by the settings in M55). The flow unit options are the same as those in M31. If "velocity 4-20mA" is selected in M55, the unit should be set to m/s.</p>
M57	<p>20mA output value</p> <p>Set the flow rate value which corresponds to 20mA output current. Refer to M31 for flow unit options.</p>
M58	<p>Current loop verification.</p> <p>Check if the current loop has been calibrated before leaving the factory. Press ENT, and use ↶ or ↷ to display 0mA, 4mA - 24mA one after another. For each one, check with an ammeter to verify that current loop output terminals agree with the displayed values. It is necessary to re-calibrate the current loop if over the permitted tolerance. For more information, refer to <i>section 3.29</i> for analogue output calibration.</p>
M59	<p>Display present output of the current loop circuit.</p> <p>Re-calibration is needed if the displayed value differs significantly from the actual output value measured with an ammeter.</p>
M60	<p>Set up system date and time. Press ENT for modification. Use the ⊙ key to skip the digits that need no modification.</p>
M61	<p>Display software version information and Electronic Serial Number (ESN) that are unique for each EUROSonic 2000 series flow meter.</p> <p>The user can use the ESN for instrumentation management</p>
M62	<p>RS-232 configuration. All the devices connected with RS232 link should have matched serial configuration. The following parameters can be configured: Baud rate (75 to 115,200 bps), parity, data bits and stop bit.</p>
M63	<p>AI1 value range</p> <p>Used to enter the temperature / press values corresponding to 4mA and 20mA input current. The displayed values have no unit, so that they can represent any physical parameters.</p>
M64	<p>AI2 value range</p> <p>Used to enter the temperature / press values represented by 4mA and 20mA input current.</p>
M65	<p>AI3 value range</p> <p>Used to enter the temperature / press values represented by 4mA and 20mA input current.</p>
M66	<p>AI4 value range</p> <p>Used to enter the temperature / press values represented by 4mA and 20mA input current.</p>
M67	<p>Window to set up the frequency range (lower limit and upper limit) for the frequency output function. Valid values: 1Hz-9999Hz. Factory default is 1-1001 Hz.</p> <p>Note that the frequency signal can only be transmitted through the OCT output. Therefore, you need to set the OCT to be in frequency output mode.</p>

Menu window No.	Function																		
M68	Window to set up the minimum flow rate which corresponds to the lower frequency limit of the frequency output																		
M69	Window to set up the maximum flow rate which corresponds to the upper frequency limit of the frequency output																		
M70	LCD backlight control. Available options: Always OFF; Always ON and Lighting For. When Lighting For option is selected, you need to enter a value which indicates how many seconds the backlight will be on with every key pressing.																		
M71	LCD contrast control. The LCD will become darker when a small value is entered.																		
M72	Working timer. It can be reset by pressing  key, and then select YES.																		
M73	Alarm #1 lower threshold setup. When flow rate is below this threshold, the Alarm #1 OCT circuit or relay will be activated. There are two alarming methods, OCT and relay. User must select the alarming output method in window M78 or M79.																		
M74	Alarm #1 upper threshold setup. When flow rate is above this threshold, the Alarm #1 OCT circuit or relay will be activated. There are two alarming methods, OCT and relay. User must select the alarming output method in window M78 or M79.																		
M75	Alarm #2 lower threshold setup. When flow rate is below this threshold, the Alarm #2 OCT circuit or relay will be activated. There are two alarming methods, OCT and relay. User must select the alarming output method in window M78 or M79.																		
M76	Alarm #2 upper threshold setup. When flow rate is below this threshold, the Alarm #2 OCT circuit or relay will be activated. There are two alarming methods, OCT and relay. User must select the alarming output method in window M78 or M79.																		
M77	Buzzer setup. If a proper input source is selected, the buzzer will beep when the trigger event occurs. The available trigger sources are: <table border="0" style="width: 100%; margin-top: 10px;"> <tr> <td style="width: 50%;">0. No Signal</td> <td style="width: 50%;">9. POS Int Pulse</td> </tr> <tr> <td>1. Poor Signal</td> <td>10. NEG Int Pulse</td> </tr> <tr> <td>2. Not Ready</td> <td>11. NET Int Pulse</td> </tr> <tr> <td>3. Reverse Flow</td> <td>12. Energy Pulse</td> </tr> <tr> <td>4. AO Over 120%</td> <td>13. ON/OFF via RS232</td> </tr> <tr> <td>5. FO Over 120%</td> <td>14. Fluid Sound Speed Changed</td> </tr> <tr> <td>6. Alarm #1</td> <td>15. Buzzer on when key down</td> </tr> <tr> <td>7. Alarm #2</td> <td>16. Buzzer off</td> </tr> <tr> <td>8. Batch Control</td> <td></td> </tr> </table>	0. No Signal	9. POS Int Pulse	1. Poor Signal	10. NEG Int Pulse	2. Not Ready	11. NET Int Pulse	3. Reverse Flow	12. Energy Pulse	4. AO Over 120%	13. ON/OFF via RS232	5. FO Over 120%	14. Fluid Sound Speed Changed	6. Alarm #1	15. Buzzer on when key down	7. Alarm #2	16. Buzzer off	8. Batch Control	
0. No Signal	9. POS Int Pulse																		
1. Poor Signal	10. NEG Int Pulse																		
2. Not Ready	11. NET Int Pulse																		
3. Reverse Flow	12. Energy Pulse																		
4. AO Over 120%	13. ON/OFF via RS232																		
5. FO Over 120%	14. Fluid Sound Speed Changed																		
6. Alarm #1	15. Buzzer on when key down																		
7. Alarm #2	16. Buzzer off																		
8. Batch Control																			

Menu window No.	Function																		
M78	<p>OCT (Open Collector Transistor output) setup.</p> <p>By selecting a proper triggering source, the OCT circuit will close when the trigger event occurs. The OCT wiring diagram is shown in <i>Appendix 9.1</i>. The available triggering sources are:</p> <table border="0"> <tr> <td>0. No Signal</td> <td>9. POS Int Pulse</td> </tr> <tr> <td>1. Poor Signal</td> <td>10. NEG Int Pulse</td> </tr> <tr> <td>2. Not Ready</td> <td>11. NET Int Pulse</td> </tr> <tr> <td>3. Reverse Flow</td> <td>12. Energy Pulse</td> </tr> <tr> <td>4. AO Over 120%</td> <td>13. FO (frequency output)</td> </tr> <tr> <td>5. FO Over 120%</td> <td>14. FO via RS232C</td> </tr> <tr> <td>6. Alarm #1</td> <td>15. ON/OFF via RS232</td> </tr> <tr> <td>7. Alarm #2</td> <td>16. Fluid Sound Speed Changed</td> </tr> <tr> <td>8. Batch Control</td> <td>17. OCT off</td> </tr> </table>	0. No Signal	9. POS Int Pulse	1. Poor Signal	10. NEG Int Pulse	2. Not Ready	11. NET Int Pulse	3. Reverse Flow	12. Energy Pulse	4. AO Over 120%	13. FO (frequency output)	5. FO Over 120%	14. FO via RS232C	6. Alarm #1	15. ON/OFF via RS232	7. Alarm #2	16. Fluid Sound Speed Changed	8. Batch Control	17. OCT off
0. No Signal	9. POS Int Pulse																		
1. Poor Signal	10. NEG Int Pulse																		
2. Not Ready	11. NET Int Pulse																		
3. Reverse Flow	12. Energy Pulse																		
4. AO Over 120%	13. FO (frequency output)																		
5. FO Over 120%	14. FO via RS232C																		
6. Alarm #1	15. ON/OFF via RS232																		
7. Alarm #2	16. Fluid Sound Speed Changed																		
8. Batch Control	17. OCT off																		
M79	<p>Relay output setup.</p> <p>By selecting a proper triggering source, the relay circuit will close when the trigger event occurs. The relay is single-pole and constant-on. The available triggering sources are:</p> <table border="0"> <tr> <td>0. No Signal</td> <td>9. POS Int Pulse</td> </tr> <tr> <td>1. Poor Signal</td> <td>10. NEG Int Pulse</td> </tr> <tr> <td>2. Not Ready</td> <td>11. NET Int Pulse</td> </tr> <tr> <td>3. Reverse Flow</td> <td>12. Energy Pulse</td> </tr> <tr> <td>4. AO Over 120%</td> <td>13. ON/OFF via RS232</td> </tr> <tr> <td>5. FO Over 120%</td> <td>14. Fluid Sound Speed Changed</td> </tr> <tr> <td>6. Alarm #1</td> <td>15. Relay off</td> </tr> <tr> <td>7. Alarm #2</td> <td></td> </tr> <tr> <td>8. Scheduled Output</td> <td></td> </tr> </table> <p>The relay output is a single-pole single-throw (SPST), always on type drive. Its maximum operating frequency is 1Hz. Its load current is 1A at 125VAC, or 2A at 30VDC.</p>	0. No Signal	9. POS Int Pulse	1. Poor Signal	10. NEG Int Pulse	2. Not Ready	11. NET Int Pulse	3. Reverse Flow	12. Energy Pulse	4. AO Over 120%	13. ON/OFF via RS232	5. FO Over 120%	14. Fluid Sound Speed Changed	6. Alarm #1	15. Relay off	7. Alarm #2		8. Scheduled Output	
0. No Signal	9. POS Int Pulse																		
1. Poor Signal	10. NEG Int Pulse																		
2. Not Ready	11. NET Int Pulse																		
3. Reverse Flow	12. Energy Pulse																		
4. AO Over 120%	13. ON/OFF via RS232																		
5. FO Over 120%	14. Fluid Sound Speed Changed																		
6. Alarm #1	15. Relay off																		
7. Alarm #2																			
8. Scheduled Output																			
M80	<p>For batch process controller.</p> <p>Select the triggering signal of the internal batch process controller:</p> <table border="0"> <tr> <td>0. Key ENT down</td> <td>4. AI2 Falling Edge</td> </tr> <tr> <td>1. AI1 Rising Edge</td> <td>5. AI3 Rising Edge</td> </tr> <tr> <td>2. AI1 Falling Edge</td> <td>6. AI3 Falling Edge</td> </tr> <tr> <td>3. AI2 Rising Edge</td> <td>7. AI4 Rising Edge</td> </tr> </table> <p>For the input analogue current signal, 0mA indicates "0" and 20mA indicates "1".</p>	0. Key ENT down	4. AI2 Falling Edge	1. AI1 Rising Edge	5. AI3 Rising Edge	2. AI1 Falling Edge	6. AI3 Falling Edge	3. AI2 Rising Edge	7. AI4 Rising Edge										
0. Key ENT down	4. AI2 Falling Edge																		
1. AI1 Rising Edge	5. AI3 Rising Edge																		
2. AI1 Falling Edge	6. AI3 Falling Edge																		
3. AI2 Rising Edge	7. AI4 Rising Edge																		
M81	<p>For batch process controller.</p> <p>Set the flow batch value (dose).</p> <p>M81 and M80 should be used together to configure the internal batch process controller.</p>																		

Menu window No.	Function
M82	<p>View the daily, monthly and yearly totalizer values.</p> <p>The flow total data of the last 64 days, last 64 months and last 5 years are saved in memory. Use EDIT, ▲/▶ (this should be the “UP” arrow) or ▼/◀ to display them.</p> <p>The first line on the screen has a dash line “-----”. Be aware if there is other letter after the dash line. If a “G” appeared, the system gained was adjusted automatically at least once. This could happen when the flow meter was offline once on that day. If a “H” appeared, poor signal was detected at least once. It indicates that there was interference or the installation was not good. Refer to the next chapter for diagnosis information.</p>
M83	<p>Automatic Amending function for automatic offline compensation.</p> <p>Select YES to enable this function, select NO to disable it.</p> <p>When the function is enabled, the flow meter will estimate the average flow uncounted (or “lost”) during the offline session and add the result to the totalizer.</p> <p>The estimation of the uncounted flow is made by computing the product of the offline time period and the average flow rate, which is the average of the flow rate before going offline and the one after going online.</p>
M84	Set the thermal energy unit.
M85	<p>Select temperature source:</p> <p>0. temperature from input AI1 and AI2;</p> <p>1. fixed difference.</p> <p>When selecting “1. fixed difference”, you need to enter the temperature difference in this window.</p>
M86	Select the specific heat value.
M87	Energy totalizer switch.
M88	Set energy multiplier factor.
M89	Reset energy totalizer.
M90	<p>Display the signal strength S (one for upstream and one for downstream) and signal quality Q.</p> <p>S, Q and R (see M91) are the so-called installation triplet. They are the key criteria for justifying whether an installation is bad, operational or optimal.</p> <p>Your installation is bad if $S < 60$, $Q < 60$ and $R < 97\%$ or $R > 103\%$.</p> <p>Your installation is operational if $S \geq 60$, $Q \geq 60$ and $97\% \leq R \leq 103\%$.</p> <p>Your installation is optimal if $S \geq 80$, $Q \geq 80$ and $99\% \leq R \leq 101\%$. Note, for high velocity flow, the optimal range for R may be relaxed.</p>
M91	<p>Display the transit time ratio R. It is one of the installation triplet.</p> <p>Refer to the above menu (M90) for more details.</p>
M92	<p>Display the fluid sound speed estimated by using the measured transit-time.</p> <p>If this value has an obvious difference with the actual fluid sound speed, the user is recommended to check if the pipe parameters are correct and if the transducer installation is good.</p>

Menu window No.	Function
M93	<p>Display the average transit time and the delta time (transit time difference between upstream and downstream traveling).</p> <p>Normally, the delta time should not fluctuate over 20%. If it does, the system is not in stable condition. You need to check your transducer installation and the entered installation parameters. For small pipe, the transit time value may not be stable. In such case, try to adjust transducer position until the transit time becomes stable.</p>
M94	<p>Display the Reynolds number and the pipe factor used by the flow rate measurement program. Pipe factor is calculated from the line-averaged velocity and cross-section-averaged velocity information.</p>
M95	<p>Upon entering into this window, the circular display function is started automatically. The following windows will be displayed one by one, each window will stay for about 4 seconds: M95->M00->M01->M02->M03->M04->M05->M06->M07->M08->M09->M90->M95. This function allows the user to visit all the important information without any manual action. To disable the function, simply switch to another window.</p>
	Not used
M96	Not used
M97	Not used
M98	Not used
M99	View the last 64 records of power on and off events. The recorded information include the date and time as well as the corresponding flow rate when the power on or off occurs
M+0	Display the total working time of the instrument since the flow meter left the factory.
M+1	Display the date and time of the last power-off event.
M+2	Display the flow rate of the last power-off event.
M+3	Display the total number of times the flow meter has been powered on and off since the flow meter left the factory.
M+4	<p>A scientific calculator for the convenience of field applications.</p> <p>All the values are in single accuracy. All the mathematic operators are selected from a list.</p>
M+5	<p>The calculator can be used while the flow meter is conducting flow measurement.</p> <p>Set fluid sound speed threshold.</p>
M+6	<p>When the estimated sound speed (M92) exceeds this threshold, an alarm signal will be generated and transmitted to OCT or relay.</p> <p>This function can be used to generate an alarm when fluid material changes.</p>
M+7	Not used
M+8	Display the received signal. In normal condition, this signal should be stable and signal amplitude does not vary much.
M+9	<p>Display the present temperature values (integer portion) of analogue input AI1 and AI2.</p> <p>Display water heat capacity at this temperature.</p>
M-0	Entry to hardware adjusting windows. Valid for the manufacturer only.

5. TROUBLESHOOTING

5.1 INTRODUCTION

The flowmeter series flow meters utilized high-reliability design, thus, their malfunction probability is quite low. However, due to improper settings, harsh environment or misuse, problem could occur. Therefore, flowmeter is equipped with a complete set of self-diagnosis functions. The errors are displayed in the upper right corner of the menu window via identification code in a timely order. Hardware self-diagnosis is conducted every time when power is on. Some errors can even be detected during normal operation. For those errors undetectable due to incorrect settings or improper testing conditions, the flow meter will also display useful information to help the user to quickly debug the error and solve the problem. There are two types of errors, one is hardware error, another is operational error. Details are presented in the following sections.

5.2 POWER-ON ERRORS

When powered on, the ultrasonic flow meter automatically starts the self-diagnosis process to find if there are any hardware and software problems. If a problem is identified, an error message will be displayed. The following table shows the possible error messages, the corresponding causes and their solutions.

TABLE 5.1 HARDWARE SELF-DIAGNOSIS ERRORS AND SOLUTIONS

Error message	Causes	Solutions
ROM Parity Error	ROM operation illegal / error	1) Reboot the system 2) Contact the manufacturer.
Stored Data Error	User-entered parameters lost.	1) Reboot the system 2) If problem persists, press ENT key to restore the factory default configuration.
SCPU Fatal Error	SCPU hardware fatal error	
System Clock Slow or Fast Error	Problem with the system clock or the crystal oscillator.	1) Reboot the system
CPU or IRQ Error	Problem with CPU or IRQ hardware	2) Contact the manufacturer.
System RAM Error	Problem with RAM chip	
Time Date Error	Problem with date/time chip	1) Initialize the calendar in menu window M61. 2) Contact the manufacturer.
No Display. Erratic or Abnormal Operation	Problem with wiring	Double check wiring connections.
No response to key pressing	Keypad is locked Bad plug connection	Unlock the keypad.
Reboot repetitively	Hardware problems	Contact the manufacturer

5.3 WORKING STATUS ERRORS

The ultrasonic flow meter will show an Error Code (a single letter like I, R, etc.) in the upper right corner on menu windows. When any abnormal Error Code shows, counter-measures should be taken.

TABLE 5.2 WORKING STATUS ERRORS AND SOLUTIONS

Error code	Message on window M08	Causes	Solutions
R	System Normal	No error	
I	No Signal	1) Unable to receive signal 2) Transducers installed improperly 3) Loosen contact or not enough couplant between transducer and pipe surface. 4) Pipe liners are too thick or the deposition inside of the pipe is too thick. 5) Transducer cables are not properly connected.	1) Polish the pipe surface and clean the spot. Remove paint. 2) Make sure the couplant is enough. 3) Make sure the transducer is in tight contact with pipe surface. 4) Check the transducer cables. 5) Check installation parameter settings. 6) Find a better measurement site. Newer pipe, no corrosion, no deposition
J	Hardware Error	Hardware problem	Contact the manufacturer
H	Poor Sig. Detected	Poor signal detected Similar to error code I	Similar to error code I
E	Current Loop Over 20mA	4-20mA loop output over 120% Improper settings for current loop output	1) Ignore it if current loop output is not used 2) Check current loop settings in M56. 3) Confirm if the actual flow rate is too high.
Q	Frequency Output Over	1) The frequency output is 120% over. 2) Improper settings for frequency output 3) The actual flow rate is too high	1) Ignore it if frequency output is not used 2) Check the values entered in window M66, M67, M68 and M69. 3) Use a larger value in M69 if needed. 4) Confirm if the actual flow rate is too high.
F	System RAM Error Date Time Error CPU or IRQ Error ROM Parity Error	1) Temporary problems with RAM, RTC 2) Permanent problems with hardware	1) Reboot the system 2) Contact the manufacturer Refer to <i>Table 5.1</i> as well
G	Adjusting Gain >s1 Adjusting Gain >s2 Adjusting Gain >s3 Adjusting Gain >s4 (shown in M00-M03)	Instrument is in the progress of adjusting the gain for the signal, and the number indicates the progressive steps	No need for action
K	Empty pipe	1) No liquid inside the pipe 2) Incorrect setup in M29	1) If the pipe is not full, relocate the meter to where the pipe is full of liquid 2) If the pipe is full, enter 0 in M29

5.4 OTHER PROBLEMS AND SOLUTIONS

1) Q: Why the instrument displays 0.0000 flow rate while the liquid in the pipe is actually flowing? The signal strength is checked to be good (the working status is "R") and the signal quality Q has a satisfactory value.

A: The problem is likely to be caused by the incorrect "Zero Point" setting. The user may have conducted the "Zero Point" setup while the flow was not standstill. To solve this problem, use the 'Reset Zero' function in menu window M43 to clear the zero point.

2) Q: The displayed flow rate is much lower or much higher than the actual flow rate in the pipe under normal working conditions. Why?

A: The entered offset value might be wrong. Enter '0' offset in window M44.

a) Incorrect transducer installation. Re-install the transducers carefully.

b) The 'Zero Point' is wrong. Go to window M42 and redo the "Zero Point" setup. Make sure that the flow inside the pipe is standstill. No velocity is allowed during this setup process.

3) Q: Why there is no signal? The installation requirements are met, pipe is new and pipe material is in good quality.

A: Check the following:

a) Is the installation method suitable for your pipe size?

b) Are the entered installation parameters correct?

c) Are the wirings correct?

d) Adequate couplant? Transducers are in good contact with pipe?

e) Is pipe full?

f) Is the transducer distance in consistency with the one

shown in M25?

g) Is transducer head/tail in the right direction?

4) Q: How to conduct measurement on an old pipe? Heavy scale inside, no signal or poor signal detected.

A: a) Check if the pipe is full of liquid.

b) Try Z method. If the pipe is close to a wall and it is hard to do Z-method installation, you may work on a vertical or inclined pipe with flow upwards.

c) Carefully select a good pipe section and fully polish/clean the installation area of the pipe surface. Apply a wide band of couplant on each transducer face. Install the transducer properly.

d) Slowly and slightly move each transducer with respect to each other around the installation point until the maximum signal is found. Be careful that the new installation location is free of scale inside the pipe and that the pipe is concentric (not distorted) so that the sound waves do not bounce outside of the proposed area.

e) For pipe with thick scale inside or outside, try to clean the scale off, if it is accessible from the inside.

NOTE



SOMETIMES THIS METHOD MIGHT NOT WORK AND SOUND WAVE TRANSMISSION IS NOT POSSIBLE BECAUSE OF THE LAYER OF SCALE BETWEEN THE TRANSDUCERS AND PIPE INSIDE WALL.

5) Q: Why no current in the current loop output?

A: Check if the current output mode is set correct in M55.

You need to turn the current loop on in M55. Check the hardware connection: open the electronics enclosure, check to see if the short-circuit terminal near terminal 22 is in place between 1-2, i.e. Direct Output Mode.

NOTE	
	POSITIONS 2-3 ARE USED FOR TRANSMITTER MODE IN WHICH AN EXTERNAL POWER SUPPLY IS NEEDED FOR THE CURRENT LOOP OUTPUT.

6) Q: Why is the current output not correct?

- A: a) Check if the current output mode is set correct in M55.*
- b) Check the upper and lower current settings in M56 and M57.*
- c) Re-calibrate the current loop. Verify the output with M49.*

7) Q: Can the flow meter work normally for a few years without stop under harsh environment where power supply voltage varies widely?

A: Yes. The flow meter employed intelligent signal processing algorithms to handle strong interference coming from either power line or radiation. It also automatically adjusts itself to the optimal operation status when sound wave strength varies due to changing environment.

6. COMMUNICATION PROTOCOL

The ultrasonic flow meter integrates a standard RS-232C communication interface and a complete set of communication protocol. Its hardware supports MODEM for phone-line based data networking. With the aid of a RS232-RS485 converter, the flow meter can be connected to a RS485 network bus. You may also use our GSM short-message module to transmit flow data to a remote computer.

When using RS232 for networking, you may use the flow meter's IDN as its network address, and use [W]-extended command set as the communication protocol. The current loop output and OCT output can be used to control analogue-based or stepper-based valve openness, and the relay output can be used to turn on and off other devices. The four channel analogue inputs can be used to input pressure, temperature and other signals. In brief, a EUROSONIC 2000 is a complete flow measurement or thermal energy measurement RTU. The maximum transmission distance is 15m for RS232C and 1000m for RS485. If longer distance is needed, current loop, MODEM, GSM can serve the purpose.

All the flow meter operations can be made on a remote computer, except the modification of IDN which can only be done locally through the flow meter's keypad. The communication protocol is based on master-slave principle. Master (remote computer) sends a command, slave (the flow meter) responses the command.

You may use the Hyper Terminal software in your computer to send commands to and view responses from the flow meter. Please refer to your computer's manual on how to configure the Hyper Terminal. Note that the COM port settings need to match those in menu window M62.

6.1 RS232 CONNECTOR PIN-OUT

RS232 WIRING DIAGRAM

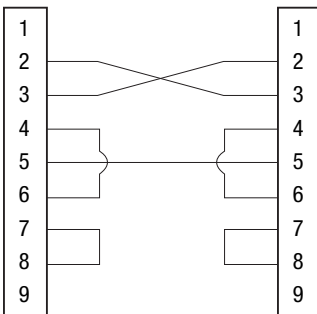

REFERENCES

Pin	Definition
1	Not Used
2	RXD
3	TXD
4	DTS
5	GND
6	DSR
7	+5V
8	Not Used
9	Ring input for connecting a modem

6.2 RS232 WIRING

Refer to Figure 7 for connecting the flow meter to a remote computer through RS232. Lines 2 and 3 of the connecting cable are crossed over. Note that the regular RS232 cable obtained in the stores cannot be used directly. You need to make modification according to Figure 6.1. Consult the User’s Manual of your computer for RS232 wiring as well.

6.3 COMMUNICATION PROTOCOL

The protocol is comprised of a set of basic commands that are strings in ASCII format, ending with a carriage (CR) and line feed (LF). Commonly used commands are listed in the following table.

6.3.1 BASIC COMMANDS

Command	Function	Data Format
DQD(CR) ¹	Return flow rate per day	±d.dddddE±dd(CR) (LF) ²
DQH(CR)	Return flow rate per hour	±d.dddddE±dd(CR) (LF)
DQM(CR)	Return flow rate per minute	±d.dddddE±dd(CR) (LF)
DQS(CR)	Return flow rate per second	±d.dddddE±dd(CR) (LF)
DV(CR)	Return instantaneous flow velocity	±d.dddddE±dd(CR) (LF)
DI+(CR)	Return POS totalizer	±dddddddE±d(CR) (LF) ³
DI-(CR)	Return NEG totalizer	±dddddddE±d(CR) (LF)
DIN(CR)	Return NET totalizer	±dddddddE±d(CR) (LF)
DIE(CR)	Return Caloric Totalizer Value	±dddddddE±d(CR) (LF)
DID(CR)	Return Identification Number (IDN)	dddd(CR) (LF)
E(CR)	Return Instantaneous Caloric Value	±d.dddddE±dd(CR) (LF)
DL(CR)	Return signal strength and signal quality	UP:dd.d, DN:dd.d, Q=dd(CR)(LF)
DS(CR)	Return the percentage of analogue output A0.	±d.dddddE±dd(CR) (LF)
DC(CR)	Return the present error code	4
DA(CR)	OCT or RELAY alarm signal	TR:s, RL:s(CR)(LF) ⁵
DT(CR)	Return the current date and time	yy-mm-dd hh:mm:ss(CR)(LF)
M@(CR)****	Send a key value as if a key is pressed	M@(CR))(LF) ⁶

Command	Function	Data Format
LCD(CR)	Return the current display contents	
C1(CR)	OCT close	
C0(CR)	OCT open	
R1(CR)	RELAY close	
R0(CR)	RELAY open	
F0dddd(CR)	Force the FO output to output a frequency of dddd Hz	Fdddd(CR)(LF)
Aoa(CR)	Output current a at the current loop output terminal	A0a(CR)(LF) ⁷
BA1(CR)	Return current value of AI1 (0-20mA)	±d.ddddddE±dd(CR) (LF)
BA2(CR)	Return current value of AI2 (0-20mA)	±d.ddddddE±dd(CR) (LF)
BA3(CR)	Return current value of AI3 (0-20mA)	±d.ddddddE±dd(CR) (LF)
BA4(CR)	Return current value of AI4 (0-20mA)	±d.ddddddE±dd(CR) (LF)
AI1(CR)	Return temperature/pressure value of AI1	±d.ddddddE±dd(CR) (LF)
AI2(CR)	Return temperature/pressure value of AI2	±d.ddddddE±dd(CR) (LF)
AI3(CR)	Return temperature/pressure value of AI3	±d.ddddddE±dd(CR) (LF)
AI4(CR)	Return temperature/pressure value of AI4	±d.ddddddE±dd(CR) (LF)
ESN(CR)	Return the electronic serial number (ESN) of the flow meter	dddddddt(CR)(LF) ⁸
W	Prefix of an IDN-addressing-based networking command. The IDN address is a word, ranging 0-65534.	⁹
N	Prefix of an IDN-addressing-based networking command. The IDN address here is a single byte value, ranging 00-255.	⁹
P	Prefix of any command with checksum	
&	Command binder to make a longer command by combining up to 6 commands	
RING(CR)(LF)	Handshaking Request from a MODEM	ATA(CR) (LF)
OK(CR)	Acknowledgement from a MODEM	No action
	Handshaking Request from a Flow meter	AT(CR) (LF)
GA(CR)	A Command for GSM messaging ¹⁰	Please contact the manufacturer for detail
GB(CR)	B Command for GSM messaging ¹⁰	
GC(CR)	C Command for GSM messaging	
DUMP ¹¹	Return the print buffer content	In ASCII string format
DUMPO	Clear the whole print buffer	In ASCII string format
DUMP1(CR)	Return the whole print buffer content	In ASCII string Format (24KB long)

Notes:

1. (CR) stands for Carriage Return. Its ASCII code is 0DH. (LF) stands for Line Feed. Its ASCII code is 0AH.
2. "d" stands for a digit number of 0~9. 0 is expressed as +0.000000E+00.
3. "d" stands for a digit number of 0~9. The number before "E" is integer.
4. Working status code, 1-6 letters. Refer to Table 5.2 for error code.
5. "s" is "ON", "OFF" or "UD". For instance, "TR:ON, RL:UD" means that the OCT is in closed state and RELAY is not used.
6. @ stands for key value. For instance, value 30H means key "0", command "M4" is equivalent to press key "4".
7. "a" stands for current value, a digit number of 0~20. For instance, A02.34, A00.2
8. "dddddddt" stands for 8-digit electronic serial number. "t" stands for flow meter type.
9. If there are more than one flow meters in a network, all the basic commands must be prefixed with N or W. Otherwise, multiple flow meters may reply to the same request.
10. Adding a GSM module to the flow meter allows the user to check flow meter flow rate and other parameters from a cell phone.
11. Used for visiting the printer buffer content.

6.3.2 PROTOCOL PREFIX USAGE

1) Prefix P

The prefix P can be added before any command in the above table to have the returning data followed with two bytes of CRC check sum, which is the adding sum of the original character string.

Take command DI+(CR) (Return POS Totalizer Value) as an example. The binary data for DI+(CR) is 44H, 49H, 2BH and 0DH. Assume the return value of this command is +1234567E+0m3(CR)(LF) (the string in hexadecimal is 2BH, 31H, 32H, 33H, 34H, 35H, 36H, 37H, 45H, 2BH, 30H, 6DH, 33H, 20H, 0DH, 0AH).

Then, the P-prefixed command, PDI+(CR), would return +1234567E+0m3!F7(CR)(LF). The '!' acts as the starter of the check sum (F7) which is obtained by adding up the string, 2BH+ 31H+ 32H+ 33H+ 34H+ 35H+ 36H+ 37H+ 45H+ 2BH+ 30H+ 6DH+ 33H+ 20H = (2) F7H.

Please note that it is allowed to not have data entry or to have SPACES (20H) character before the '!' character.

2) Prefix W

The prefix W is used for networking commands. The format of a networking command is:

W + IDN address string + basic command.

The IDN address should have a value between 0 and 65534, except 13(0DH), 10 (0AH), 42(2AH,*), 38(26H, &).

For example, if you want to visit the instantaneous flow velocity of device IDN=12345, the following command should be sent to this device: W12345DV(CR). The corresponding binary code is 57H, 31H, 32H, 33H, 34H, 35H, 44H, 56H, 0DH.

3) Prefix N

The prefix N is a single byte IDN network address, not recommended in a new design.

4) Command binder &

The & command binder or connector can connect up to 6 basic commands to form a longer command so that it will make the programming much easier.

For example, assume we want device IDN=4321 to return the flow rate, velocity and POS totalizer value simultaneously. The combined command would be W4321DQD&DV&DI+(CR), and the result would be:
 +1.234567E+12m3/d(CR)
 +3.1235926E+00m/s(CR)
 +1234567E+0m3(CR)

6.4 THE M COMMAND AND THE ASCII CODES

The protocol provides the capability of virtual key-pressing. A remote RS-232C terminal can send an 'M' command along with a key code to simulate the scenario that the key is pressed through the keypad of the flow meter. This functionality allows the user to operate the flow meter in the office far away from the testing site.

For example, the command "M1" is sent to the flow meter through the RS-232C link, the flow meter will treat the command as if the user has pressed the (1) key through the keypad.

The ASCII codes and corresponding key values of the keypad keys are listed in the following table.

Key	Hexadecimal Key Code	Decimal Key Code	ASCII Code
(0)	30H	48	0
(1)	31H	49	1
(2)	32H	50	2
(3)	33H	51	3
(4)	34H	52	4

Key	Hexadecimal Key Code	Decimal Key Code	ASCII Code
(5)	35H	53	5
(6)	36H	54	6
(7)	37H	55	7
(8)	38H	56	8
(9)	39H	57	9
(.)	3AH	58	:
(←)	3BH, 0BH	59	;
(MEM)	3CH, 0CH	60	<
(ENT)	3DH, 0DH	61	=
(↗/÷)	3EH	62	>
(↘/~)	3FH	63	?

6.5 PROGRAMMING EXAMPLES

Example 1: VB requests the instantaneous (in second) flow rate.

VB Code: mscom1.input = "dqs" + vbcrflf;

Example 2: VB requests the 4321 flow meter to return the following data with checksum: (a) instantaneous flow rate; (b) instantaneous flow velocity; (c) Positive totalizer value; (d) Heat totalizer value; (e) AI1 input current; (f) AI2 input current.

VB Code: mscom1.input = "W4321PDQD&PDV&PDI+&PDIE&PBA1&PAI2" + vbcrflf;

Example 3: VB requests to change the pipe OD to 345mm.

VB Code: mscom1.input = "M<" + VBCRLF + "M1" + VBCRLF + "M1" + VBCRLF + "M3" + VBCRLF + "M4" + VBCRLF + "M5" + VBCRLF + "M=" + VBCRLF

Note that "M<" represents the (MEM) key, "M=" represents the (ENT) key, "M1" represents the (1) key.

7. MEASUREMENTS OF THERMAL AND OTHER PHYSICAL PARAMETERS

7.1 INTRODUCTION

The standard model flow meter has two analogue input modules built into its hardware system. It can accommodate three other analogue input modules. These modules provides five analogue channels, AI1 – AI5, which can be connected to analogue sensors to measure physical quantities, such as temperature, pressure, etc. By combining the flow rate information, the meter can provide very valuable information for resources management and process control.

For thermal energy measurement (or caloric measurement), two temperature transmitters are required to be installed on the measuring site, one on the supply side of the flow, and the other on the return side. They should provide accurate temperature data to the flowmeter through analogue input channels AI1 and AI2. Their signals must be 4-20mA or 0-20mA standard current signals.

All the results can be sent to a master computer through the built-in serial port (see *chapter 6* for the communication). This means that a flowmeter can be used as a RTU in a flow monitoring network. It helps to reduce the cost and complexity while improving the reliability of a monitoring network.

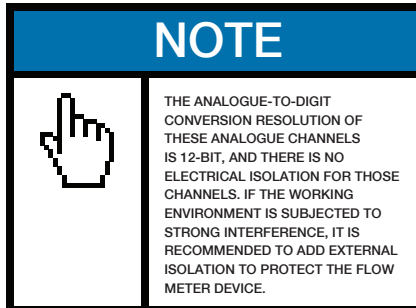

7.2 WIRING ANALOGUE INPUTS

For caloric measurement, the supply side temperature transmitter should be connected to channel AI1 (terminal blocks 64 and 63), and the return side transmitter should be connected to channel AI2 (terminal blocks 65 and 63) with twisted-pair wiring (Figure 8-1). An internal +24VDC power is proved to the terminals, thus, no external power supply is needed. This means *that the temperature (or pressure) transmitter must be two-wire type transmitter.*

Menu window M06 displays the current analogue input data and its corresponding pressure or temperature value. The flowmeter can accommodate five analogue signals with its five analogue input modules. AI1 and AI2 are available in standard options. The other three modules are available only upon request.

ANALOGUE INPUT WIRING

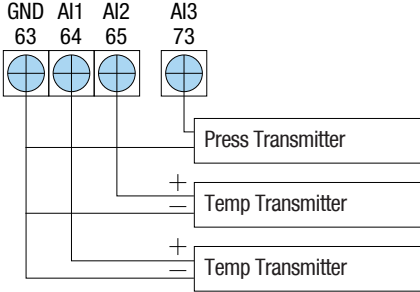

f. 8

7.3 THERMAL ENERGY MEASUREMENT

There are two methods for thermal energy calculation:

- 1) $Q_t = Q \times (T_2 - T_1) \times C_t$,
- 2) $Q_t = Q \times (TC_2 - TC_1)$

Where Q_t is the thermal energy (or caloric) consumed, Q is the flow rate, T_1 and T_2 are the temperature at supply and return points, respectively.

C_t is the specific heat (or the thermal capacity coefficient) of the fluid, which can be entered in menu M86. For water, it is normally about 0.0041868GJ/m³°C.

TC_1 and TC_2 are the thermal capacities corresponding to temperature T_1 and T_2 , which are calculated by the flow meter according to international standards and displayed in M05.

The following menu windows might be used when performing thermal energy measurement:

Menu window M05: display energy and totalized energy.

Menu window M06: display the current values of input AI1 and AI2 and their corresponding temperature values.

Menu window M63: set the minimum and maximum temperature values which correspond to the minimum current (4mA) and maximum current (20mA) of channel AI1.

Menu window M64: set the minimum and maximum temperature values which correspond to the minimum current (4mA) and maximum current (20mA) of channel AI2.

Menu window M84: thermal unit selection.
KCAL/s - Kilocalories/second, GJ/s – Giga Joules/second

Menu window M85: temperature source selection:
0. temperature from input AI1 and AI2; 1. fixed difference. When selecting fixed difference, enter the difference in this menu.

Menu window M86: specific heat (or thermal capacity coefficient) input.

Menu window M87: thermal totalizer on/off switch

Menu window M88: thermal totalizer multiplier factor

Menu window M89: thermal totalizer reset

NOTE

IF THE FLUID TEMPERATURES AT BOTH SUPPLY AND RETURN POINTS ARE STABLE, YOU MAY CHOOSE NOT TO USE TEMPERATURE TRANSMITTERS. INSTEAD, YOU CAN DIRECTLY ENTER THE TEMPERATURE DIFFERENCE OF THE TWO POINTS ON MENU WINDOW M85.

7.4 CONFIGURE ANALOGUE MEASUREMENT RANGES

Temperature, pressure and other signals are entered into the flow meter through analogue channels AI1-AI4. Their measurement ranges can be set on windows M63-M66. The first number of these windows is the minimum of the measurement range, corresponding to an analogue input of 4mA. The second number is the maximum, corresponding to 20mA input current.

Example 1:

Assume a temperature transmitter provides 4mA at 10 ° C and 20mA at 150 ° C. And this transmitter is connected to channel AI1. Then, you need to enter 10 and 50 at menu window M63 for the first and second numbers, respectively. You can view the present current signal value and corresponding temperature data from window M06.

Example 2:

Assume a pressure transmitter outputs current 4mA at 0.98kg pressure and 20mA at 10.5kg pressure. The transmitter is connected to channel AI3. Then, you need to enter 0.98 and 10.5 in window M65. The present values of input current and corresponding temperature are shown in M07.

If you find the current value from the transmitter is different from the one shown in M06 (or M07), you need to calibrate the corresponding analogue channel. Please see *section 3.16* for calibration detail.

7.5 READ INPUT ANALOGUE VALUES FROM A NETWORK COMPUTER

When the flow meter is networked, all the analogue data can easily be visited from a remote computer. For visiting the present analogue input current, use command BA1, BA2, BA3 or BA4.

For visiting the temperature/pressure value represented by the analogue input current, use command AI1, AI2, AI3 or AI4.

8. WARRANTY AND SERVICE

8.1 WARRANTY

The products manufactured by EUROMAG INTERNATIONAL are warranted to be free from defects in materials and workmanship for a period of one year from the date of shipment to the original purchaser. EUROMAG INTERNATIONAL's obligation should be limited to restoring the meter to normal operation or replacing the meter, at EUROMAG's choice, and shall be conditioned upon receiving written notice of any alleged defect within 10 days after its discovery. EUROMAG INTERNATIONAL will determine if the return of the meter is necessary. If it is, the user should be responsible for the one-way shipping fee from the customer to the manufacturer.

EUROMAG INTERNATIONAL is not liable to any defects or damage attributable to miss usage, improper installation, out-of-spec operating conditions, replacement of unauthorized parts and acts of nature. Besides, fuses and batteries are not part of this warranty.

THE FOREGOING WARRANTY IS EXCLUSIVE AND IN LIEU OF ALL OTHER EXPRESS OR IMPLIED WARRANTIES (INCLUDING BUT NOT LIMITED TO WARRANTIES OF MERCHANTABILITY AND FITNESS FOR A PARTICULAR PURPOSE, AND WARRANTIES ARISING FROM DEALING, TRADE OR USAGE.)

8.2 SERVICE

For operational problems, please contact the technical support department by telephone, fax, email or internet. In most cases, problems could be solved immediately.

For any hardware failure of the instrument, we recommend our customers to send back the instrument for service. Please contact the technical support department with the model number and serial number of the unit before sending the unit back to us. Both numbers can be found on the product label. For each service or calibration request, we will issue a Return Materials Authorisation (RMA) number.

Take notice that the cost for repairing can only be determined after receipt and inspection of the instrument. A quotation will be sent to the customer before proceeding with the service.

Important Notice for Product Return

Before returning the instrument for warranty repair or service, please read the following carefully:

1. If the return item has been exposed to nuclear or other radioactive environment, or has been in contact with hazardous material which could pose any danger to our personnel, the unit cannot be serviced.
2. If the return item has been exposed to or in contact with dangerous materials, but has been certified as hazard-free device by a recognized organization, you are required to supply the certification for the service.
3. If the return item does not have a RMA# associated, it will be sent back without any service conducted.

9. APPENDIX

9.1 WIRING DIAGRAM AND OUTLINE DRAWINGS

The following wiring diagram is for standard version of the flowmeter.

The internal structure of the standard version of the flowmeter is shown in the following picture. All the wiring terminal blocks are located on the lower part of the box, right above the interface label. The terminal block pins are numbered and marked right below the pins.

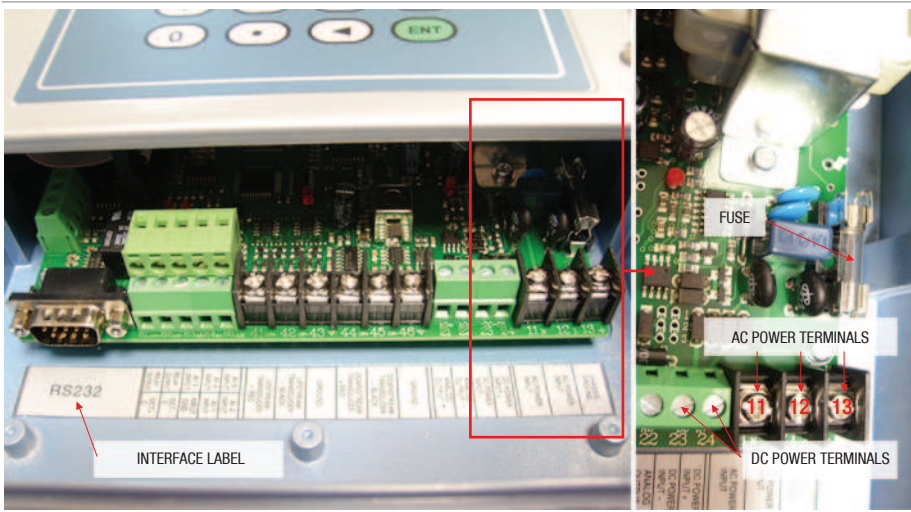

f.9

Line Voltage and Fuse Ratings:

For 8-36VDC power supply: 3.0A Slo-Blo

For 110VAC power supply: 1.0A Slo-Blo

For 220VAC power supply: 0.5A Slo-Blo

As indicated in the right picture, the fuse is located on the lower right corner of the unit, right below the keypad panel. If you want to replace the fuse, you may need to remove the keypad panel to have better access.

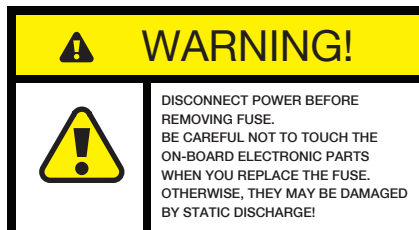

WIRING DIAGRAM

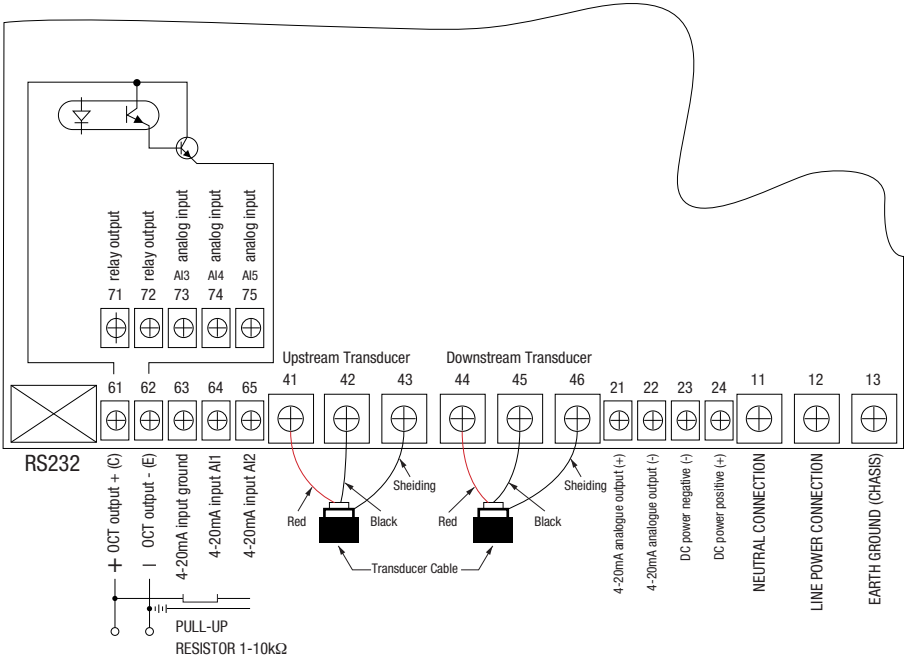

f. 10

OUTLINE DIAGRAM

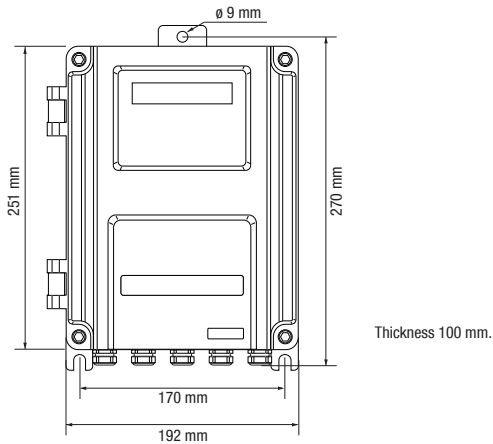

f. 11

9.2 CLAMP-ON TRANSDUCER INSTALLATION GUIDE

9.2.1 CHOOSE INSTALLATION METHOD

The following three installation methods are often used in normal applications. Select the right installation method according to your pipe size.

V-method Installation

V-method installation is commonly used with pipe diameters ranging from 1" (30mm) to 4" (100mm). It is also called reflective method.

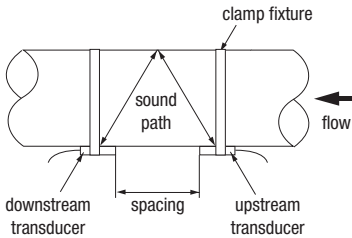

f. 12

Z-method Installation

Z-method is commonly used when the pipe diameter is between 4" (100mm) and 240" (6,000mm). This is method often yields the best signal return.

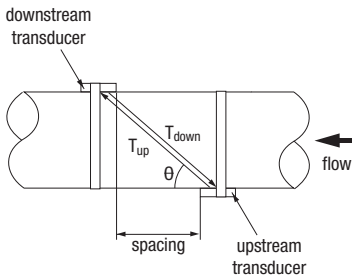

f. 13

W-method Installation

W-method is used on small pipes, usually smaller than 1.1/2" (40mm).

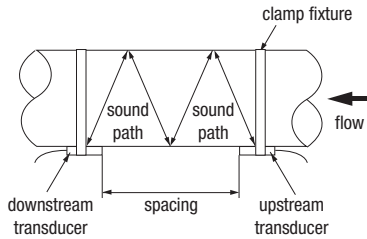

f. 14

9.2.2 TRANSDUCER SPACING

The flowmeter will calculate the transducer spacing for you. All you need to do is to enter all the installation information, including installation method, pipe parameters, fluid parameters, etc., through menu windows M11-M24. The spacing value will be displayed on menu window M25.

The transducer spacing is referred to the distance between the two ends of the two transducers (see the figure 15).

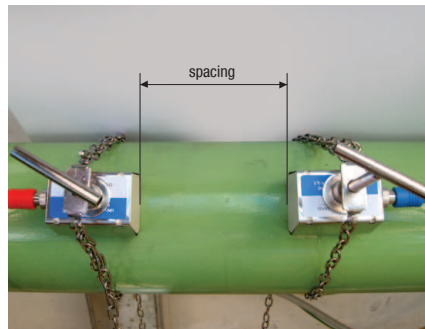

f. 15

9.2.3 PREPARE THE PIPE SURFACE

Locate the installation site according to the site selection rules suggested in *section 2.8*.

Based on the transducer spacing obtained in the above step, approximately mark the area of the pipe surface where the transducers will be mounted.

Clean the marked area. Remove rust and paint. Sand the surface if not smooth. Use wet cloth to wipe off the powder after sanding. Dry up the surface. A dry, clean surface will ensure a good acoustic bond between transducer and pipe.

Based on the transducer spacing, accurately mark the transducer installation spots on the pipe surface. Make sure the two spots are in the cleaned area.

9.2.4 PREPARE THE TRANSDUCERS

Clean the transducer surface. Keep the surface dry. Apply a wide band of ultrasonic couplant down the centre of each transducer face as shown on the figure 16. Also apply a band of couplant on the pipe surface. If the couplant is very sticky, you may need to slightly massage the pipe surface with the couplant so that the couplant can fill up the tiny pits which may exist on pipe surface.

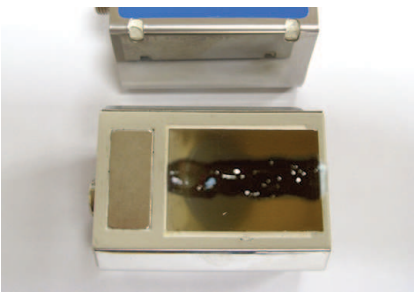

f. 16

9.2.5 INSTALL THE TRANSDUCERS

NOTE	
	FOR HORIZONTAL PIPE LINE, IT IS RECOMMENDED TO INSTALL THE TRANSDUCERS ON THE SIDE INSTEAD OF ON THE TOP OR BOTTOM OF THE PIPE. THIS IS TO AVOID AIR BUBBLES ON THE TOP AND SEDIMENTS ON THE BOTTOM OF THE PIPE.

First, mark the transducer installation location on the pipe surface according to the mounting spacing given in menu M25. You may need to make a paper template to help you accurately and quickly locate the transducer positions as well as to center the transducers, especially if you plan to use Z-method for the installation.

Z-METHOD

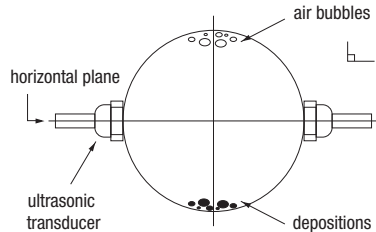

f. 17

Then, connect the mounting fixture around the pipe. Leave the chain loose so you can slip the transducer underneath.

Apply a small amount of couplant in the prepared area of the pipe where transducers will be in contact. Slip the transducer under the clamp fixture. Tighten the screw. Do the same thing for the other transducer. Use the figure on the right as a reference.

If the pipe material is metal, you do not need the

clamp fixture. The transducers will automatically attach to the pipe by magnetic force. You may need to press the transducer against the pipe with certain strength in order to make the contact tight.

Finally, connect the transducers to the main unit with the preferred transducer cables. Refer to *section 2.2.2* for more information.

9.2.6 FINE TUNE THE INSTALLATION

Switch to menu window M90 and then M91. Check the readings of the triplet (signal strength S, signal quality Q and transit-time ratio R). Make sure they are at least in the operational ranges:

Operational Ranges:

$$S \geq 60, Q \geq 60, 97\% \leq R \leq 103\%.$$

Optimal Ranges:

$$S \geq 80, Q \geq 80, 99\% \leq R \leq 101\%*.$$

** Note that when flow velocity is very high, the range for R may be wider.*

In ideal case where pipe condition and fluid condition are favourable for sound propagation, the triplet readings could be fine turned into the optimal ranges. If your triplet readings are not close to their optimal ranges, or, even not in their operational ranges, you need to adjust your transducer installation slightly and slowly, until you get the best readings.

If you are unable to get the triplet into their operational ranges, no matter how hard you try, then, you may need to check all the parameters you entered in menu windows M11 to M24. Make sure those values are correct. Whenever you make a change to those

parameters, you need to check the transducer spacing reading in menu M25. If the spacing is changed, you need to reinstall the transducers accordingly.

If you still cannot get the right triplet readings, check the following:

- Is the pipe too old?
- Too much deposition inside of the pipe?
- Too much corrosion? Too much air bubble?
- Too thick liner? Empty or half-full pipe?
- Too close to pump / valve / elbow?

Please refer to *section 2.11* for more suggestions.

<h2 style="margin: 0;">NOTE</h2>	
	<p>ULTRASONIC COUPLANT CAN BE SILICON, EPOXY, GREASE, OR VASELINE. SILICON CAN LAST FOR A LONG TIME AND IS THUS NORMALLY RECOMMENDED. PLEASE READ THE INSTRUCTIONS ON THOSE PRODUCTS CAREFULLY BEFORE USING THEM. EUROMAG INTERNATIONAL WILL NOT BE RESPONSIBLE FOR ANY CONSEQUENCES CAUSED BY THESE PRODUCTS.</p>

9.3 STANDARD PIPE DIMENSIONS

As pipe dimensions can vary between countries and standards please search pipe manufacturers on line in your country for standard charts.

9.4 SOUND SPEED TABLES

Table 9.5.1: Sound Speed in Water at atmosphere pressure. Unit: t (°C) v (m/s)

t	v	t	v	t	v	t	v
0	1402.3	25	1496.6	50	1542.5	75	1555.1
1	1407.3	26	1499.2	51	1543.5	76	1555.0
2	1412.2	27	1501.8	52	1544.6	77	1554.9
3	1416.9	28	1504.3	53	1545.5	78	1554.8
4	1421.6	29	1506.7	54	1546.4	79	1554.6
5	1426.1	30	1509.0	55	1547.3	80	1554.4
6	1430.5	31	1511.3	56	1548.1	81	1554.2
7	1434.8	32	1513.5	57	1548.9	82	1553.9
8	1439.1	33	1515.7	58	1549.6	83	1553.6
9	1443.2	34	1517.7	59	1550.3	84	1553.2
10	1447.2	35	1519.7	60	1550.9	85	1552.8
11	1451.1	36	1521.7	61	1551.5	86	1552.4
12	1454.9	37	1523.5	62	1552.0	87	1552.0
13	1458.7	38	1525.3	63	1552.5	88	1551.5
14	1462.3	39	1527.1	64	1553.0	89	1551.0
15	1465.8	40	1528.8	65	1553.4	90	1550.4
16	1469.3	41	1530.4	66	1553.7	91	1549.8
17	1472.7	42	1532.0	67	1554.0	92	1549.2
18	1476.0	43	1533.5	68	1554.3	93	1548.5
19	1479.1	44	1534.9	69	1554.5	94	1547.5
20	1482.3	45	1536.3	70	1554.7	95	1547.1
21	1485.3	46	1537.7	71	1554.9	96	1546.3
22	1488.2	47	1538.9	72	1555.0	97	1545.6
23	1491.1	48	1540.2	73	1555.0	98	1544.7
24	1493.9	49	1541.3	74	1555.1	99	1543.9

Table 9.5.2: Sound Speed and Viscosity Data of Liquids

Liquids	Sound Speed @ 25° (77°F)		Kinematic Viscosity X 10 ⁻⁶	
	m/s	ft/s	m ² /s	ft ² /s
Acetone	1,174	3,851.7	0.399	4.293
Acetaldehyde Alcohol	1,180	3,870		
Alcohol	1,207	3,960	1.396	15.02
Aviation kerosene	1,298	4,257		
Benzene	1,306	4,284.8	0.711	7.65
Carbine	1,121	3,677		
Ethanol	1,207	3,690	1.39	14.956
Ethyl benzene	1,586 (20°)	4,389.8 (68°F)	0.797 (17°)	8.575 (63°F)
Ethylene chloride	1,193	3,914	0.61	6.563
Ethylene trichloride	1,050	3,444		
Gasoline	1,250	4,100	0.8	0.1980
Gasoline 66#	1,171	3,841		
Gasoline 80#	1,139	3,736		
Glycol	1658	5,439.6		
50%Glycol / 50%H2O	1,578	5,177		
Glycerin	1,904	6,246.7	757.1	8,081.8
Ketone	1,310	4,297		
Kerosene	1,420	4,658	2.3	24.7
Oil (Castor)	1,477	4,854.8	0.670	7.209
Oil (Diesel)	1,250	4,101		
Oil (Peanut)	1,458	4,783.5		
Petroleum	1,290	4,231		
Tetrachlor-Methane	926	3,038.1	0.607	6.531
Toluene	1,328 (20°)	4,357 (68°F)	0.644	6.929
Water, distilled	1,498	4,914.7	1.0	10.76

Table 9.5.3: Sound Speed Data of Solids

Material	Sound Speed Shear Wave (25°)		Sound Speed Long. Wave (25°)	
	m/s	ft/s	mm/us	in/us
Steel, 1% Carbon, hardened	3,150	10,335	5.88	0.2315
Carbon Steel	3,230	10,598	5.89	0.2319
Mild Steel	3,235	10,614	5.89	0.2319
Steel, 1% Carbon	3,220	10,565		
302 Stainless Steel	3,120	10,236	5.690	0.224
303 Stainless Steel	3,120	10,236	5.640	0.222
304 Stainless Steel	3,141	10,306	5.920	0.233
304L Stainless Steel	3,070	10,073	5.790	0.228
316 Stainless Steel	3,272	10,735	5.720	0.225
347 Stainless Steel	3,095	10,512	5.720	0.225
Aluminum	3,100	10,171	6.32	0.2488
Aluminum (rolled)	3,040	9,974		
Copper	2,260	7,415	4.66	0.1835
Copper (annealed)	2,235	7,628		
Copper (rolled)	2,270	7,448		
CuNi (70%Cu 30%Ni)	2,540	8,334	5.03	0.1980
CuNi (90%Cu 10%Ni)	2,060	6,759	4.01	0.1579
Brass (Naval)	2,120	6,923	4.43	0.1744
Gold (hard-drawn)	1,200	3,937	3.24	0.1276
Inconel	3,020	9,909	5.82	0.2291
Iron (electrolytic)	3,240	10,630	5.90	0.2323
Iron (Armco)	3,240	10,630	5.90	0.2323
Ductile Iron	3,000	9,843		
Cast Iron	2,500	8,203	4.55	0.1791
Monel	2,720	8,924	5.35	0.2106
Nickel	2,960	9,712	5.63	0.2217
Tin, rolled	1,670	5,479	3.32	0.1307
Titanium	3,125	10,253	6.10	0.2402
Tungsten, annealed	2,890	9,482	5.18	0.2039
Tungsten, drawn	2,640	8,661		
Tungsten, carbide	3,980	13,058		
Zinc, rolled	2,440	8,005	4.17	0.1642
Glass, Pyrex	3,280	10,761	5.61	0.2209
Glass, heavy silicate flint	2,380	7,808		
Glass, light borate crown	2,840	9,318	5.26	0.2071
Nylon	1,150	3,772	2.40	0.0945

It continues in the following page

It comes from the previous page

Material	Sound Speed Shear Wave (25°)		Sound Speed Long. Wave (25°)	
	m/s	ft/s	mm/us	in/us
Nylon,6-6	1,070	3,510		
Polyethylene (LD)			2.31	0.0909
Polyethylene (LD)	540	1,772	1.94	0.0764
PVC,CPVC	1,060	3,477	2.40	0.0945
Acrylic	1,430	4,690	2.73	0.1075
Asbestos Cement			2.20	0.0866
Tar Epoxy			2.00	0.0787
Mortar			2.50	0.0984
Rubber			1.90	0.00748



Euromag International SRL

Via Torino 3-35035 - Mestrino

PADOVA - ITALY

Tel. +39/049.9005064

Fax. +39/049.9007764

Mail. euromag@euromag.com

<http://www.euromag.com>